

— CHELSOM —

LIGHTING EDITION 27



THE QUEEN'S AWARDS
FOR ENTERPRISE:
INTERNATIONAL TRADE
2017



THE QUEEN'S AWARDS
FOR ENTERPRISE:
INTERNATIONAL TRADE
2020

Copyright 2020 Chelsom Ltd



CONTENTS

ABOUT US

Design 2-3
Manufacturing 4-5
Bespoke 6-11
Hospitality 12-17
Marine 18-23
Bar and Restaurant 24-27
Restoration 28-29
Technology 30-31
Corporate Social Responsibility 32

EDITION 27 RANGE

Collections 33-122
Reading 123-143
Desk 144-157
Bathroom 158-167
Table & Floor 168-193
Wall 194-241
Ceiling 242-315
Shades 316-319

Technical Reference 320
Conversion Chart 321
Index 322-325
Terms & Conditions 326-327



GOOD PRODUCT **DESIGN** IS AT THE FOREFRONT OF EVERYTHING WE DO

—
WE APPRECIATE THAT IN ORDER TO STAND
OUT IN OUR GLOBAL MARKETPLACE, WE
MUST CONSTANTLY INNOVATE WITH DESIGN.

Led by Robert and Will Chelsom, our in-house design team continuously strives to redefine our lighting collections by reacting to the ever-changing demands and trends that exist within the global hospitality and marine interiors sectors. Our product design is not limited to aesthetics and should incorporate function, durability, the latest technology and value engineering. The Chelsom design ethos is reflected in these catalogue pages and all custom and bespoke design concepts are welcomed.



Copyright 2020 Chelsom Ltd

WE HAVE OVER 70 YEARS EXPERIENCE OF **MANUFACTURING** HIGH QUALITY DECORATIVE LIGHTING

BY OFFERING A FIRST-CLASS LEVEL OF SERVICE WE ARE ABLE TO KEEP UP WITH THE FAST PACE AND CHALLENGING DEMANDS OF THE GLOBAL CONTRACT INDUSTRY.

Blending lean and practical production techniques, we create products for both our standard in-house collections as well as bespoke items. Our engineering and production teams in UK and China focus heavily on quality management and our skills and experience allow us to deliver lighting products using a variety of materials and finishes for all applications at suitable prices.



PROJECT MANAGEMENT

By combining proficient project management skills with industry knowledge we ensure that all projects are executed effectively from design concept stage through to CAD realisation, prototyping, tendering, purchasing, production, delivery and, where required, installation.



Copyright 2020 Chelsom Ltd



**MANDARIN
ORIENTAL**
Project: Mandarin Oriental
Hyde Park London.
Client: Mandarin Oriental
Hotel Group.
Designer: Joyce Wang Studio.

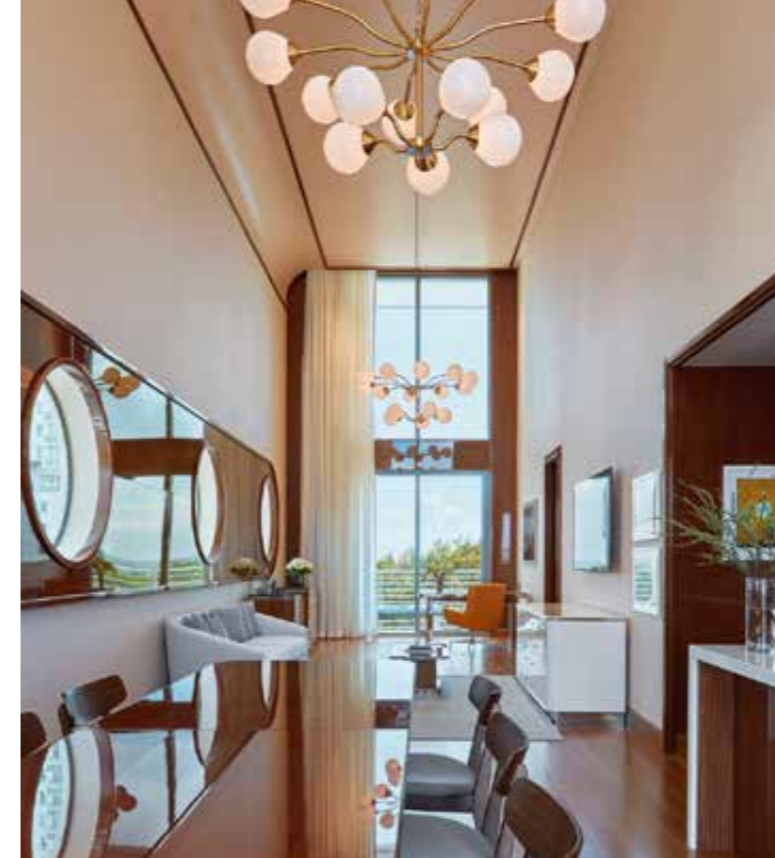

MR C
Project: Mr. C Coconut Grove, Miami.
Client: Mr. C Hotels.
Designer: Martin Brudnizki Design Studio.
Photography: Courtesy of James McDonald Photography.

“Chelsom are good at problem solving, they listen carefully and undertake bespoke work on a collaborative basis, they're as eager to deliver a perfect solution as we are. Their technical support and knowledge of production techniques is excellent they are good at helping us navigate the relationship between the desired aesthetic and the given budget.”

Richard McCready-Hughes
Creative Director
Goddard Littlefair

OUR **BESPOKE** MANUFACTURING EXPERIENCE HELPS INTERIOR ARCHITECTS REALISE THEIR DESIGN CONCEPTS

OUR FULLY FLEXIBLE APPROACH ALLOWS US TO WORK COLLABORATIVELY WITH SOME OF THE WORLD'S LEADING INTERIOR AND LIGHTING DESIGNERS.

Whether a one-off statement installation for public areas or a thousand-piece production run for hotel bedrooms or ship cabins, we will work hard to ensure that our client's vision can become a reality. Our experience in our particular field allows us to offer advice and guidance, adding manufacturing know-how, technology and value engineering to any aesthetic brief.

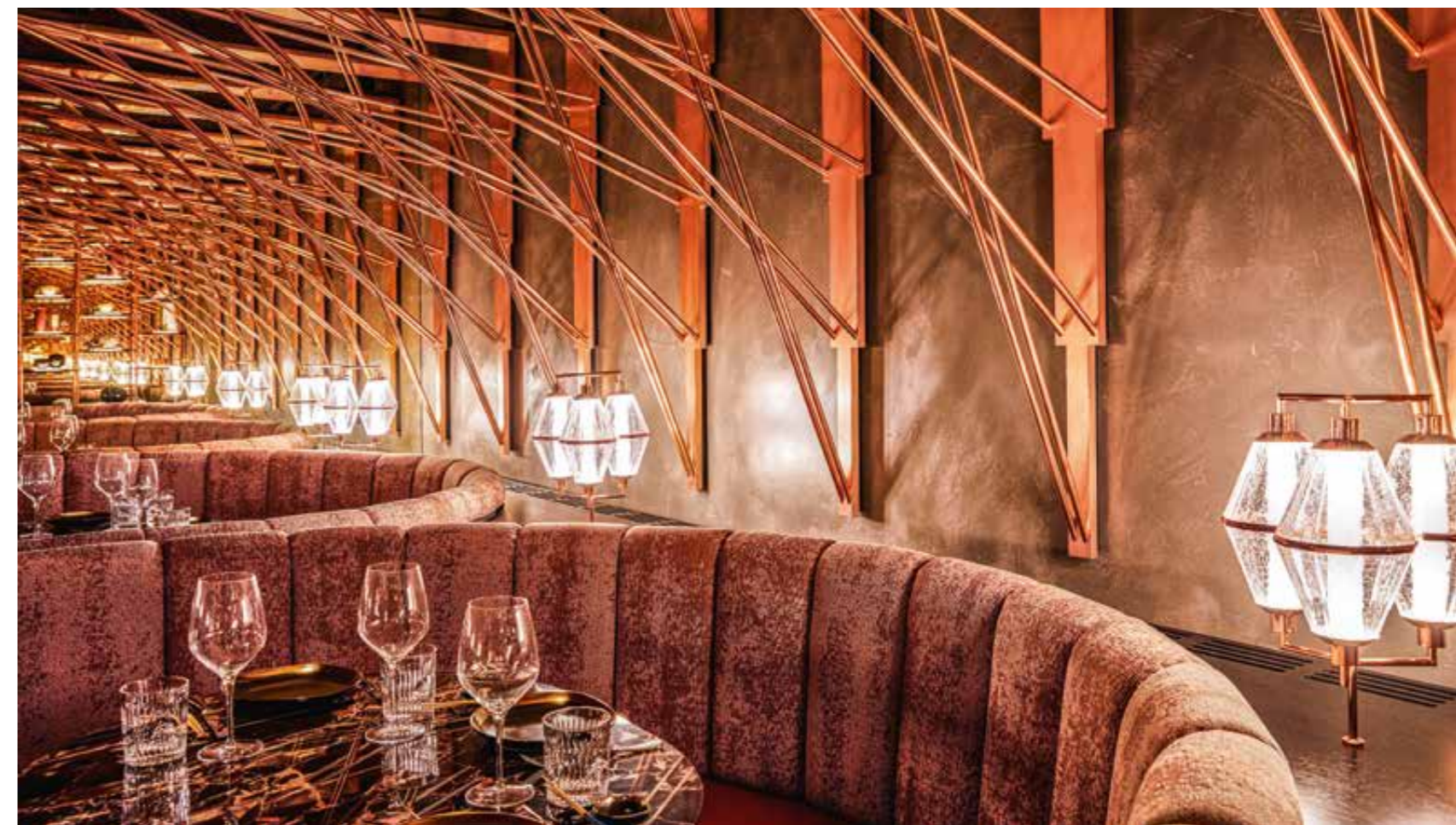

JIN GUI
Project: JIN GUI Restaurant, Hamburg.
Client: Tortue Hotels.
Designer: Joyce Wang Studio.

Copyright © 2020 Chelsom Ltd



SYMPHONY
 Project: Symphony of the Seas.
 Client: Royal Caribbean International.
 Designer: BG Studio International Inc.
 Photography: Courtesy of Michel Verdure.



CROWNE PLAZA
 Project: Crowne Plaza London, Albert Embankment.
 Client: IHG Hotels and Resorts.
 Designer: ADS Design.



CELEBRITY
 Project: Celebrity Edge.
 Client: Celebrity Cruises.
 Designer: BG Studio International Inc.
 Photography: Courtesy of Michel Verdure.

BESPOKE DESIGN PROCESS

At Chelsom, our highly skilled CAD and design teams will work to produce 3D technical drawings and full colour renders as well as 3D print models so that all bespoke designs can be tested and examined before any prototyping process begins, giving full confidence to our customers.

Copyright 2020 Chelsom Ltd



RIGGS
 Project: Riggs Washington DC.
 Client: Preferred Hotels & Resorts.
 Designer: Lore Studio.



UNIVERSITY ARMS
 Project: University Arms, Cambridge.
 Client: University Arms, Cambridge.
 Designer: Martin Brudnizki Design Studio.



JIN GUI
 Project: JIN GUI Restaurant, Hamburg.
 Client: Tortue Hotels.
 Designer: Joyce Wang Studio.

Copyright 2020 Chelsom Ltd

LIGHTING SUPPLY PARTNER TO THE **HOSPITALITY** MARKET WORLDWIDE

—
OUR LIGHTING COLLECTIONS ARE DESIGNED SPECIFICALLY WITH HOTEL INTERIORS IN MIND.

To create the perfect hotel lighting collection, we understand there is a need for product functionality, practicality and durability alongside great aesthetics. Not only that, we know that there has to be significant levels of flexibility to service this challenging marketplace as lighting products often have to conform to different international regulations, meet certain low energy requirements and be compatible with complex hotel guestroom control systems.

MR C

Project: Mr. C Coconut Grove, Miami.
Client: Mr. C Hotels.
Designer: Martin Brudnizki Design Studio.
Photography: Courtesy of James McDonald Photography.



ALEX

Project: Alex, Lake Zurich.
Client: Campbell Gray Hotels.
Designer: Brady Williams.



KIMPTON

Project: Kimpton Fitzroy, London.
Client: Kimpton Hotels & Restaurants.
Designer: Tara Bernerd & Partners.

COLLABORATION

We have longstanding deep relationships with hotel operators, interior designers, FF&E procurement companies and contractors all over the world. We collaborate with and service these key customers across the hotel industry, working at all price points and to all design briefs. By truly understanding lead time requirements, budget constraints and having wide experience in onsite engineering and installation, at Chelsom we truly are experts in this specialist field.

Copyright 2020 Chelsom Ltd





RITZ CARLTON
 Project: Ritz Carlton, Berlin.
 Client: Marriot International.
 Designer: GA Design.

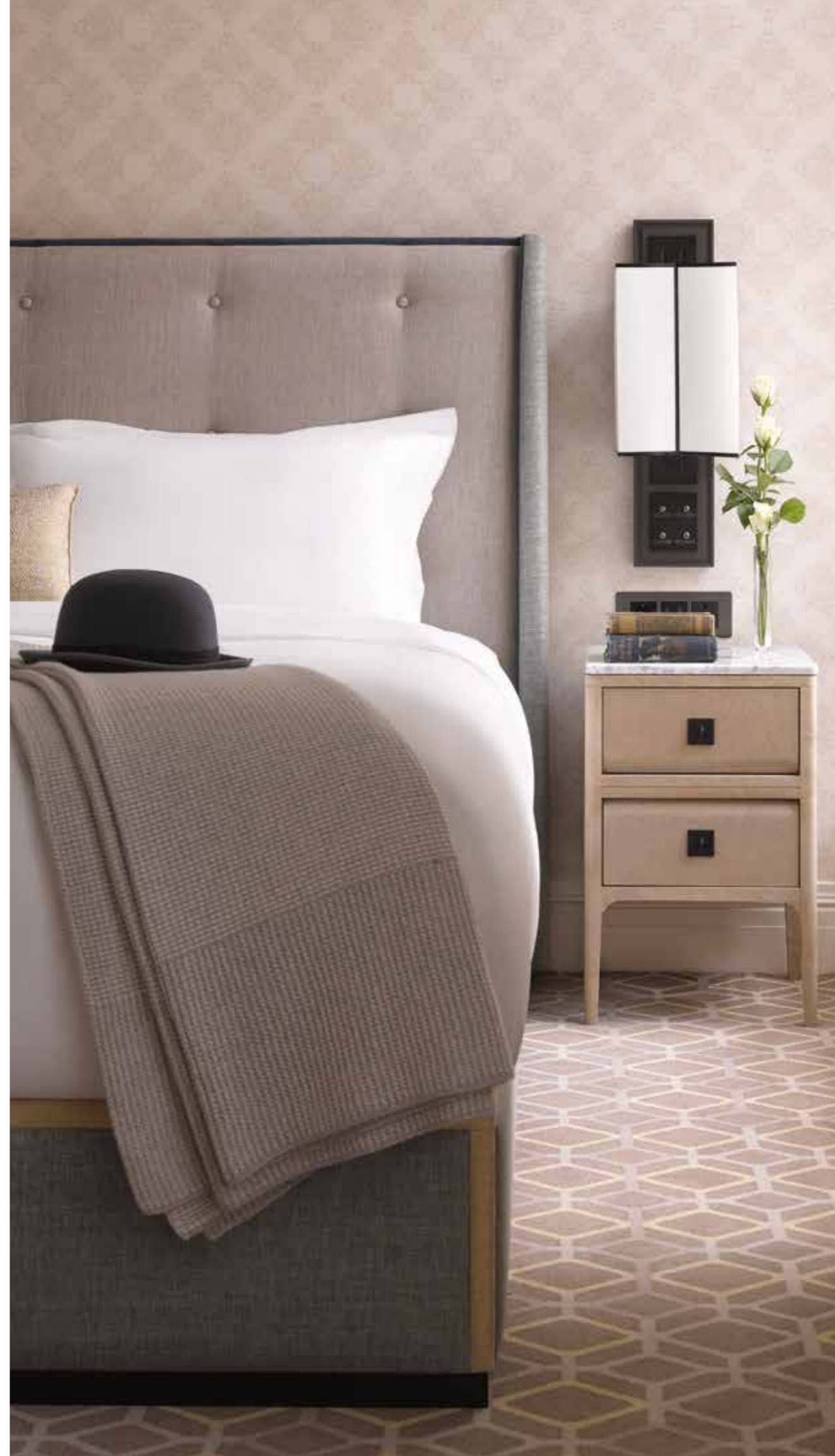

GREAT SCOTLAND YARD
 Project: Great Scotland Yard Hotel, London.
 Client: Hyatt Hotels Corporation.
 Designer: Hirsch Bedner Associates.
 Photography: Courtesy of Will Pryce.

MANDARIN ORIENTAL

Project: Mandarin Oriental Hyde Park, London.
 Client: Mandarin Oriental Hotel Group.
 Designer: Joyce Wang Studio.



“Chelsom has been a great resource for The Parker Company. We can depend on Chelsom for a quality product, timely delivery and with the end result being a satisfied client, it makes our efforts worthwhile.”

Nancy Smith
 Senior Project Director
 The Parker Company



LE MERIDIEN
 Project: Le Meridien Hotel, Florida.
 Client: Marriott International.
 Designer: Dash Design.



ABBEY
 Project: Abbey Hotel, Bath.
 Client: Abbey Hotel.
 Designer: Street Design Partnership.
 Photography: Courtesy of Derryn Vranck Photography.



MANDARIN ORIENTAL
 Project: Mandarin Oriental Hyde Park, London.
 Client: Mandarin Oriental Hotel Group.
 Designer: Joyce Wang Studio.

Copyright 2020 Chelsom Ltd

CELEBRITY
Project: Celebrity Edge.
Client: Celebrity Cruises.
Designer: Kelly Hoppen Interiors.
Photography: Courtesy
of Michel Verdure.



GLOBAL LEADERS IN THE SUPPLY OF **MARINE** LIGHTING FOR CRUISE SHIPS, FERRIES AND LUXURY YACHTS

—
WORKING CLOSELY WITH THE WORLD'S LEADING CRUISE SHIP OPERATORS, SHIPYARDS AND LEADING NAVAL INTERIOR DESIGNERS AND ARCHITECTS, WE UNDERSTAND THE SPECIFIC REGULATIONS AND DEMANDS OF THE MARINE INDUSTRY.

We are able to apply our flexible manufacturing and engineering expertise to ensure that our standard product collections as well as all customised product can suit the sea faring environment. We have a specialist team of onsite engineers who regularly travel the globe to carry out complex lighting installations on board ships.



Symphony of the Seas

CELEBRITY
Project: Celebrity Edge.
Client: Celebrity Cruises.
Designer: Jouin Manku.
Photography: Courtesy of Michel Verdure.



Copyright 2020 Chelsom Ltd



ANNA KATHARINA
 Project: MS Anna Katharina.
 Client: Scylla AG.
 Designer: In-house designer.

INDUSTRY KNOWLEDGE

At Chelsom we have specific marine sales, engineering and project management teams who fully understand the challenging nature of shipbuilding, not least of all the need to produce robust and compliant maritime lighting products that meet budget guidelines and that can be delivered within challenging project lead times. Whether manufacturing thousands of cabin lights or producing a one-off centrepiece for a cruise ship atrium, we can apply all of our industry knowledge and experience to ensure that our marine projects run smoothly.



BACH
 Project: Crystal Bach.
 Client: Crystal Cruises.
 Designer: AD Associates.
 Photography: Courtesy of Crystal Cruises.



SYMPHONY
 Project: Symphony of the Seas.
 Client: Royal Caribbean International.
 Designer: BG Studio International Inc.
 Photography: Courtesy of Michel Verdure.

Copyright 2020 Chelsom Ltd

"The cruise ship newbuild and refurbishment environments are fast paced and have a lot of demanding design challenges. Whether supplying thousands of bedside lights to cabins or manufacturing complex custom designs for our public spaces, Chelsom are a hugely knowledgeable and experienced lighting partner for our design and build teams at Carnival."

Petu Kummala
Senior Director
Interior Design & Architecture,
New Builds and Refurbishments
Carnival Cruise Line



CELEBRITY

Project: Celebrity Edge.
Client: Celebrity Cruises.
Designer: Kelly Hoppen Interiors.
Photography: Courtesy of Michel Verdure.

HARMONY

Project: Harmony of the Seas.
Client: Royal Caribbean International.
Designer: Project International Ltd.



CELEBRITY

Project: Celebrity Edge.
Client: Celebrity Edge.
Designer: Patricia Urquiola S.P.A.
Photography: Courtesy of Michel Verdure.

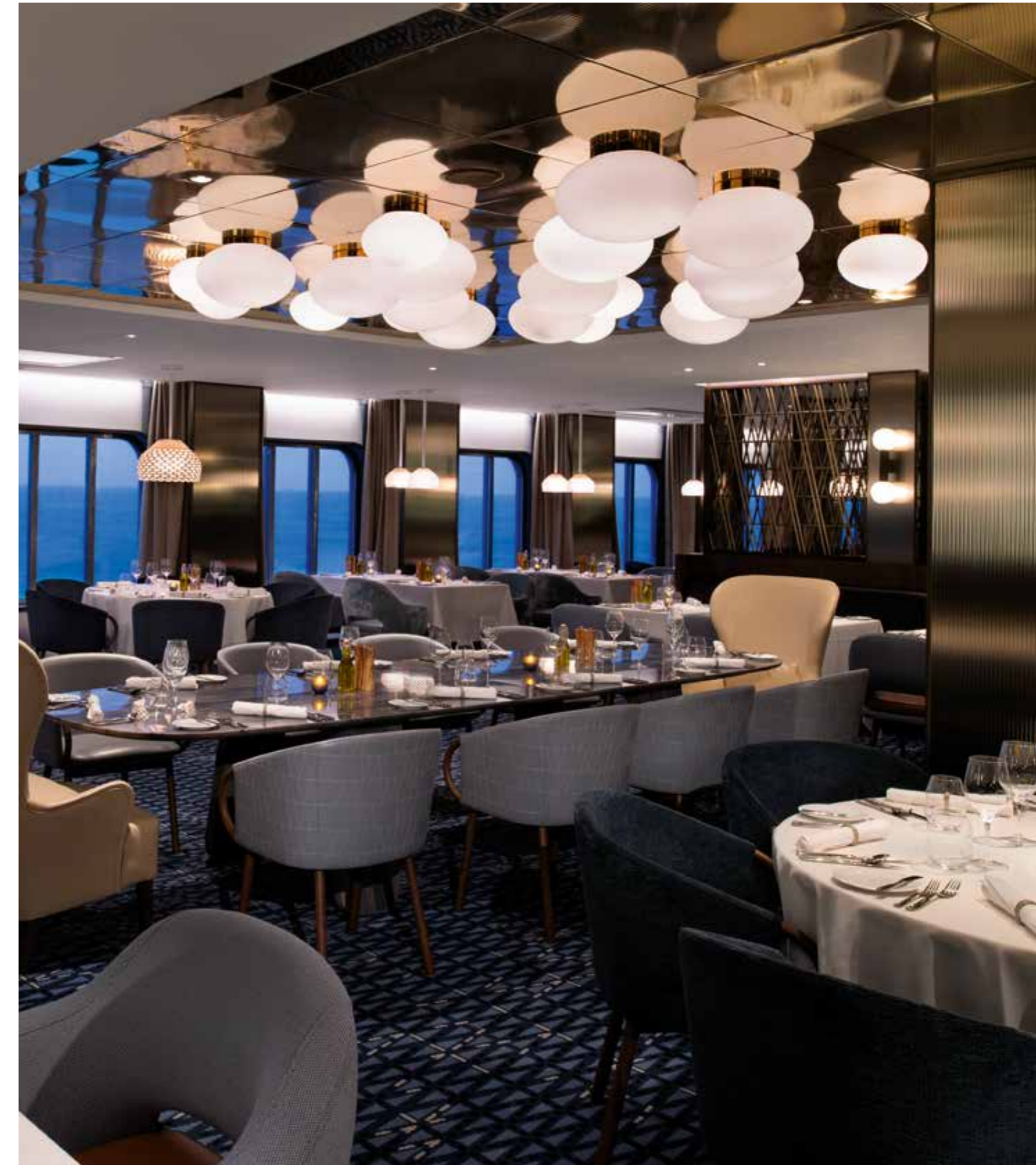

Copyright 2020 Chelsom Ltd



MRC
 Project: Mr. C Coconut Grove, Miami.
 Client: Mr. C Hotels.
 Designer: Martin Brudnizki Design Studio.
 Photography: Courtesy of James McDonald Photography.

WE WORK WITH THE FINEST **BAR & RESTAURANT** INTERIOR DESIGNERS WORLDWIDE

DESIGNERS ARE FOREVER PUSHING THE BOUNDARIES WHEN IT COMES TO CREATING MEMORABLE SPACES IN THE FOOD AND BEVERAGE SECTOR MEANING RESTAURANTS AND BARS ARE MORE THAN JUST PLACES TO EAT AND DRINK, THEY ARE RICH AND MULTI-SENSORY EXPERIENCES WHERE AMBIENCE IS KEY.

At Chelsom, our extensive standard lighting collection serves as the perfect complement to any restaurant and bar interior whilst our in-house teams will work exclusively with interior designers and customers to create one off bespoke lighting products. Light levels, dimming and control are all crucial when creating the ideal lighting scheme for bars and restaurants so our technical teams will also collaborate to ensure the perfect results are achieved.



AMARONE
 Project: Amarone Restaurant, Aberdeen.
 Client: Di Maggio's Restaurant Group.
 Designer: In-house Designer.

"We have worked with Chelsom on a number of projects including Mondrian, Sanderson and St. Martin's Lane Hotels in London and they are our first port of call when it comes to decorative lighting. Their capacity to deliver on a project, combined with their knowledge, technical capabilities and flexibility means that they are always able to surpass our expectations whilst working within budgets."

Joan Cardy
 Owner and CEO
 The Cardy Group



Copyright 2020 Chelsom Ltd

ALEX
 Project: Alex, Lake Zurich.
 Client: Campbell Gray Hotels.
 Designer: Brady Williams.



SOUTHSIDE SCRAN
 Project: Southside Scran, Edinburgh.
 Client: The Kitchin Group.
 Designer: Burns Design.

MACHRIE
 Project: The Machrie Hotel and Golf Links.
 Client: Campbell Gray Hotels.
 Designer: Peter Young Design.



Copyright 2020 Chelsom Ltd



JIN GUI
 Project: JIN GUI Restaurant, Hamburg.
 Client: Tortue Hotels.
 Designer: Joyce Wang Studio.



ROSEWOOD
 Project: Rosewood London.
 Client: Rosewood Hotels & Resorts.
 Designer: Tony Chi and Associates.

MASTERS IN THE **RESTORATION** OF PERIOD LIGHTING

—
 WE ARE REGULARLY INVOLVED IN REFURBISHING PERIOD LIGHTING AND OUR SPECIALISTS ARE TRAINED IN THE FINE ART OF LIGHTING RESTORATION.

Whether upgrading wiring and technology, refinishing metalwork, replacing missing components or simply cleaning and refurbishing fittings, we are able to transform antique and original lighting pieces with modern light sources whilst remaining sympathetic to the original period aesthetics.



ANTIGUA
 Project: St John's Cathedral, Antigua.
 Client: Diocese of North Eastern Caribbean and Aruba.

Copyright © 2020 Chelsom Ltd

EXPERTISE IN THE LATEST TECHNOLOGY FOR HOSPITALITY AND MARINE LIGHTING

NEVER BEFORE HAS TECHNOLOGY PLAYED SUCH AN IMPORTANT ROLE IN DECORATIVE LIGHTING.

Although it is product aesthetics that drives our design ethos, we truly understand that this needs to coexist with the ever evolving technical landscape. Our fast-paced client base demands that we constantly have access to the latest technologies available so that our lighting products can better enhance an interior space. LED technology is utilised in all of our product ranges and we work hard to ensure our products can comply with sophisticated dimming and control systems.

As a fully global business, we work to all relevant international safety and compliance standards and with all of the major international regulatory bodies to ensure the highest possible standards are kept. Our highly capable in-house technical teams are fully experienced in all aspects of technical lighting.



PRODUCTS AND EQUIPMENT

We partner with the highest quality providers of LED chips, lighting electronics, dimming systems, switching parts, retro-fit lamps and other electrical component suppliers to ensure that the quality and controllability of our lighting is first class. We understand that lighting ambience and hotel guest experience can be compromised if a technical lighting brief is misinterpreted. Our teams are 100% flexible and can work to any technical brief in order to bring the technical lighting vision put forward by interior and lighting designers to life. Amongst a variety of state-of-the-art equipment we have our own in-house photometric testing so we can test, produce and integrate light sources to achieve specific light levels, customised colour temperatures, or specific CRI (Colour Rendering Index).

TESTING AND REGULATIONS

At Chelsom factories in the UK and China, continual investment means the latest manufacturing and testing equipment drives on the quality of our product. As standard we work to CE, UL and SASO standards but can happily work to any international regulatory standard as required to allow access to multiple markets. We are regularly audited to ensure 100% compliance across all areas.



TECHNICAL AND DESIGN MODIFICATIONS

Our vast engineering and technical flexibility allows us to be one of the leading custom lighting suppliers in the industry. We understand that every project may require a certain technical modification in order to ensure it is totally suitable for application, especially when working across different countries. We will often modify standard product by simply changing plug types or modifying dimensions and we can modify products to incorporate convenience points for added functionality. Examples of this could be the introduction of charging ports, power outlets and USB sockets in the base of table lamps or perhaps the introduction of a switch to the stem of a floor lamp.

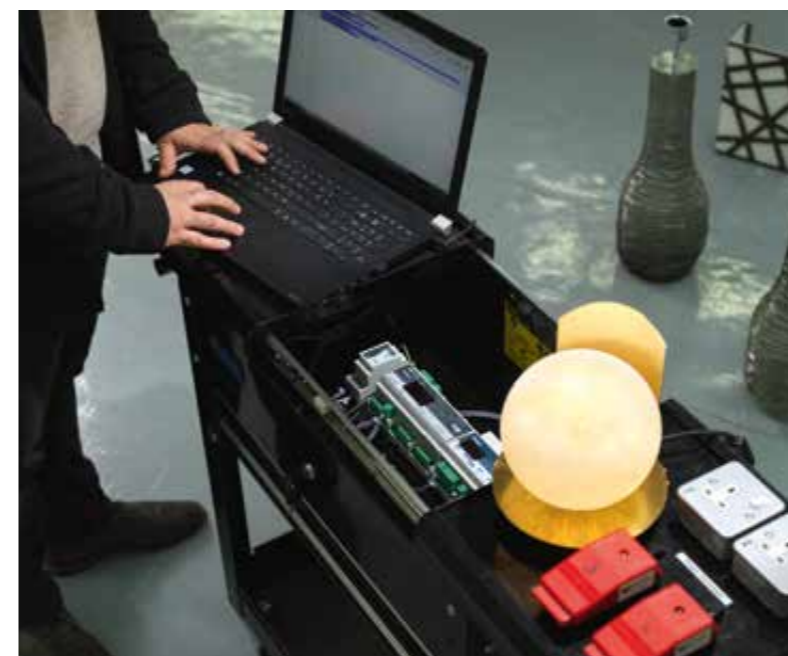

DIMMING AND CONTROL

Whether using retrofit lamps or integrated LED light sources, we can work closely with customers to ensure compatibility with all dimming and guest control systems. Most of our products comply with either Phase dimming or 1-10V dimming systems as standard. However, we can work in partnership with designers and electrical contractors on a huge range of specialist control protocols, such as DALI, DMX and Casambi. At our in-house laboratories we will always test products with the relevant dimming systems as part of our overall quality and technical control process.



If you have any specific requests or queries about any aspect of technical lighting, please contact the Chelsom team on sales@chelsom.co.uk.

CARING FOR THE **ENVIRONMENT** AND OUR LOCAL COMMUNITY



AS A LEADING GLOBAL SUPPLIER OF CONTRACT LIGHTING, WE UNDERSTAND THE POTENTIAL IMPACT OF OUR OPERATIONS.

We strive to have positive impact on both the environment and the local community so we have specific internal committees in place that meet regularly in order to look at ways we can achieve this.

ENVIRONMENTAL AWARENESS

We have various policies in place to reduce our impact on the environment covering all aspects of our operations: energy consumption, supply chain management, travel & transport, materials, resources and waste management. We have teamed up with several entities to help us on our journey to becoming more carbon efficient – see examples below:



After recently participating in the Low Carbon Innovation Forum with Lancaster University, Managing Director, Will Chelsom, has been able to apply a lot of sustainable thinking to various areas of our business and we are continuing to look at other ways we can collaborate with this highly innovative organisation.



In 2020, the MaCaW project looked at Chelsom's carbon footprint and identified a number of ways it can be reduced, which we are already starting to address. Our entire management team are fully invested and committed to this low carbon ethos.



Through its Net Zero Carbon programme, our official freight partner, Kuehne + Nagel, actively contribute to the reduction of CO2 in transport and logistics worldwide. With the support of its customers, Kuehne + Nagel has set itself a goal of transporting completely CO2 neutral by 2030.



This catalogue is printed on carbon balanced paper. Carbon Balancing is delivered by World Land Trust, an international conservation charity, whose Carbon Balanced Programme offsets emissions through the purchase and preservation of high conservation value forests.



Our full environmental policy can be found on our website at www.chelsom.co.uk.

SOCIAL RESPONSIBILITY

Chelsom has been an employer in the Blackpool area for over 70 years, with strong ties to our local community. Our CSR committee are forever engaged in looking at ways to help those less fortunate in our surrounding areas. We are delighted to say that we have partnered with two fantastic charities in the area for whom we raise money and awareness. We have also implemented a volunteering scheme whereby all employees are entitled to take paid leave to work with local charities of their choice throughout the year. Our chosen charities are listed below:



Providing bespoke support services in small groups to enable children to learn and practice essential life skills, Aspired Futures helps local young people facing various difficult challenges, fears and obstacles in life. They believe that every child and young person deserves to feel valued and respected and is entitled to the guidance they need in order to become independent, happy and safe at school, at work and in the community. At Chelsom, we fully share this belief and we want to try and be part of this solution.



Streetlife have helped homeless young people aged between 16 and 25 across Blackpool, Fylde and Wyre for over 35 years. Through their state-of-the-art Day Centre and Emergency Night Shelter, Streetlife have provided shelter, support, advice, counselling, food and toiletry parcels and therapeutic activities for the most vulnerable young people in the area. We are committed to supporting Streetlife as they carry out this important and inspiring work.

COLLECTIONS



COLLECTIONS



The Chelsom Value Award is given to ranges which represent exceptional value alongside high design and quality standards.

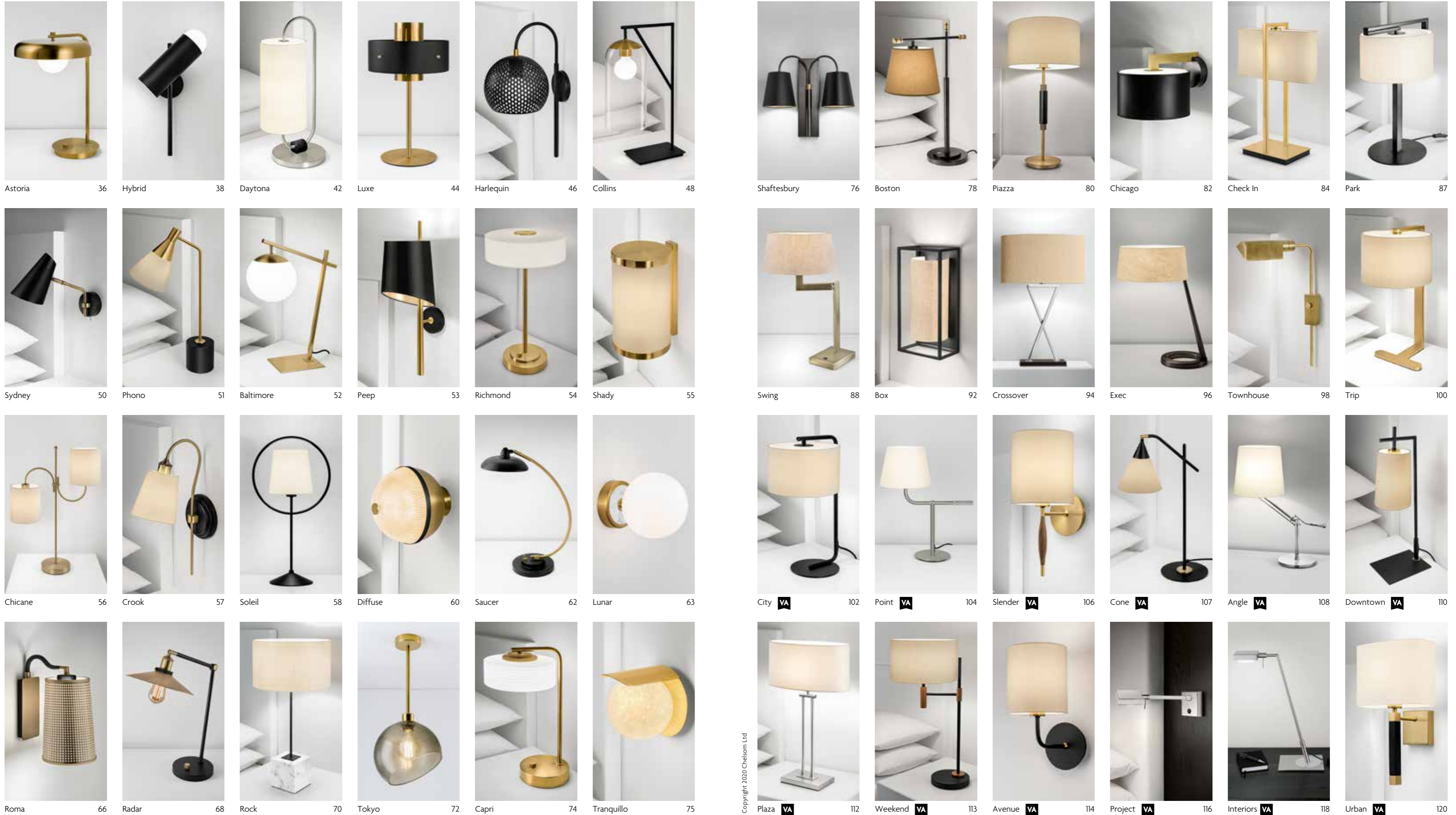

ASTORIA

Features: Shallow domed metal shades cover matt Opal blown glass globes which are threaded for secure fixing. Table lamps have rotary dimmer switches.

Materials:
Steel and glass.

Finishes:
Brushed Brass (BRB), Brushed Nickel (BN), or Satin Black with Brushed Brass (BL/BRB). Matt Opal glass. Metal shade interiors are white.

AS/36/TL/BL/BRB

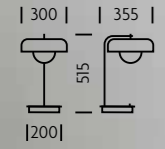

1 x E14 3.5W LED 2700K

CE U_L IP20



AS/36/WI/BRB

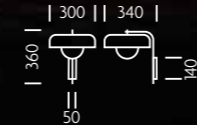

1 x E14 3.5W LED 2700K

CE U_L IP20

AS/36/WI/BL/BRB



AS/36/WI/BN



Copyright 2020 Chelsom Ltd



HYBRID



HYBRID

Features: A striking overscaled cylindrical head gives ambient room light through the matt Opal glass top dome and directional task light from below. Heads swivel right/left with a mechanical stop to prevent over rotation.

Materials: Steel and glass with acrylic diffuser.

Finishes: Brushed Brass (BRB), Brushed Nickel (BN), or Satin Black (BL).



Copyright 2020 Chelsom Ltd

DAYTONA

Features: Tall cylinder fabric shades are seemingly held within a looped tubular frame. The frame passes through a chunky cylinder in contrasting Satin Black. Floor lamps have three lamps to spread light evenly. Shades have Opal acrylic top diffusers.

Materials:
Steel with acrylic diffuser.

Finishes:
Brushed Brass with Satin Black (BRB/BL) or Brushed Nickel with Satin Black (BN/BL).

Shades:
Shades are bespoke for Daytona. Other fabrics available.



LUXE

Features: Satin Black metal outer shades with rolled edges enclose Brushed Brass cylinder shades with vertical slots to allow a warm spill of ambient light. Outer shades are fixed with knurled screw heads and table and floor lamps stand on flush bases with decorative washers.

Material:
Steel.

Finish:
Brushed Brass with
Satin Black.

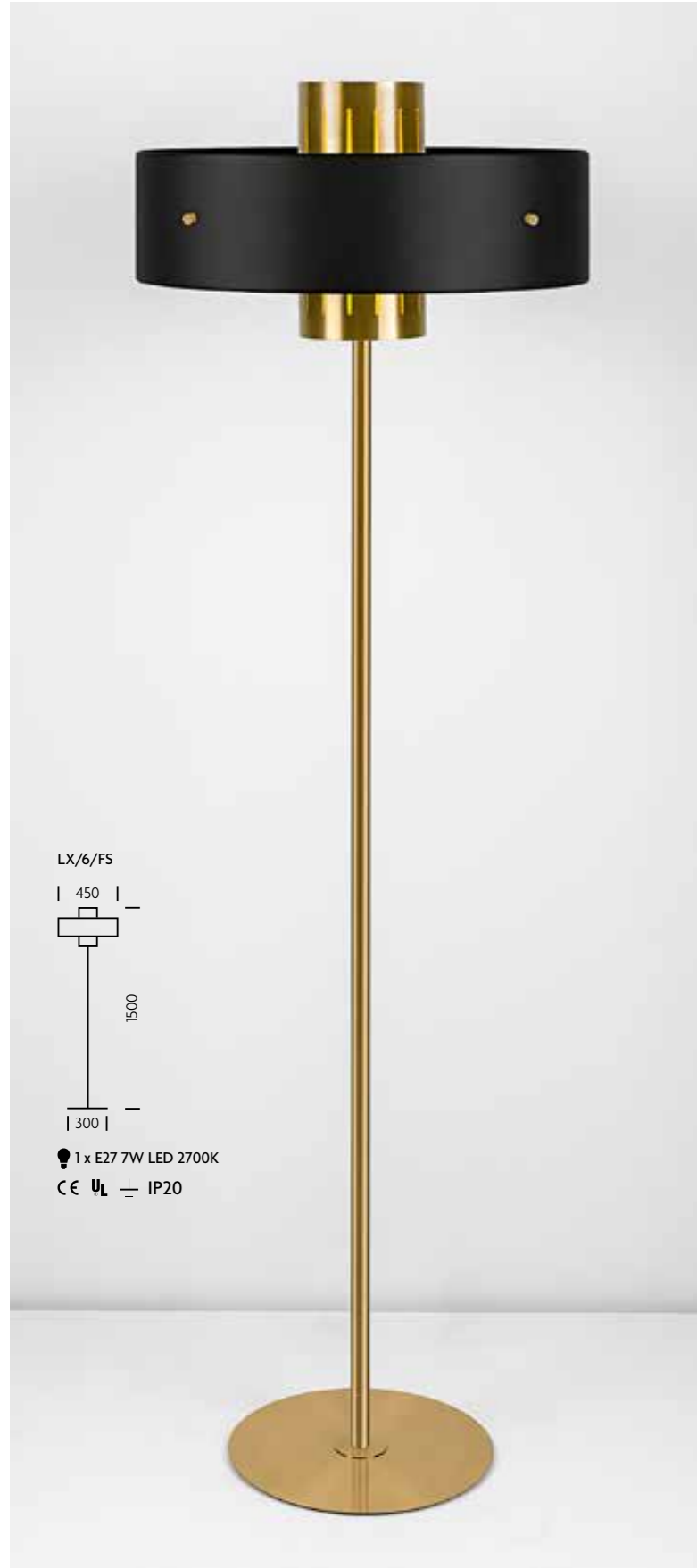

Copyright 2020 Chelsom Ltd

HARLEQUIN

Features: A metal globe shade has diamond shaped perforations allowing a glow of light from the internal globe lamp. The perforations produce delicate light patterns onto surrounding surfaces. Wall light, HQ/15/W1, can also be ceiling mounted. **THE RANGE IS PRICED WITH AND COMES COMPLETE WITH LAMPS AS SHOWN.**

Material:
Steel.

Finish:
Satin Black with
Brushed Brass.



HQ/16/W1
| 270 |
460
100
[200]
1 x E27 6W LED 2700K
CE UL IP20



HQ/15/P
100
11
Min 350/1
Max 270
[200]
Weight 1.05kg
1 x E27 6W LED 2700K
CE UL IP20

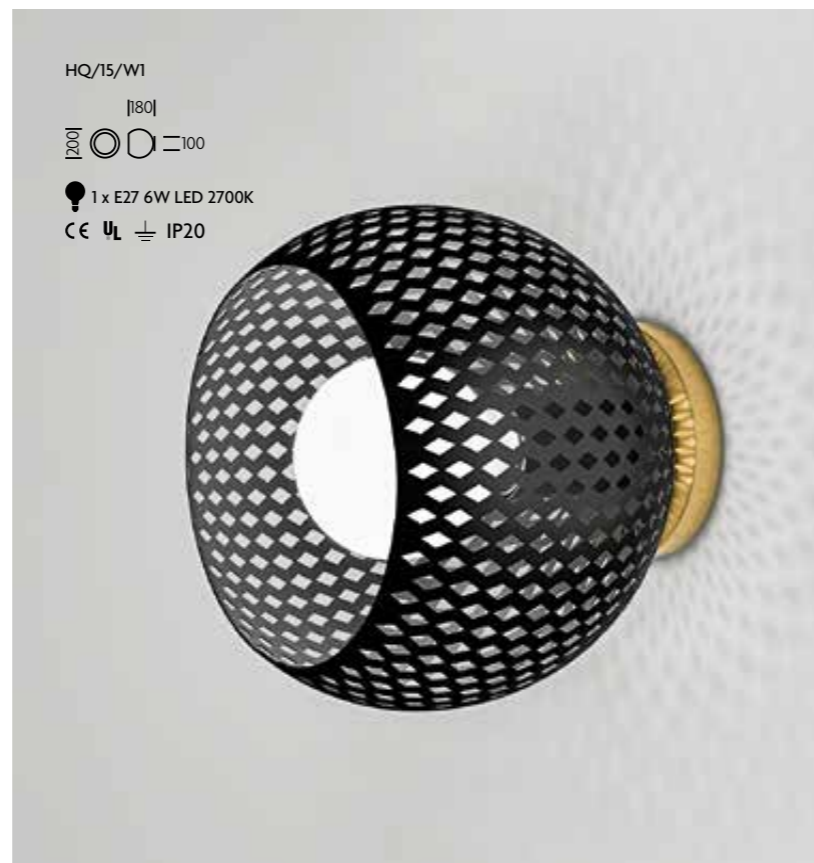

HQ/15/W1
[180]
[200] 100
1 x E27 6W LED 2700K
CE UL IP20



HQ/15/TL
| 320 |
610
[200]
1 x E27 6W LED 2700K
CE UL IP20

Copyright 2020 Chelsom Ltd

COLLINS

Features: Cantilevered arms support brass-capped Clear glass bell shades. Opal globe lamps give a soft internal glow from within. **THE RANGE IS PRICED WITH AND COMES COMPLETE WITH LAMPS AS SHOWN.**

Materials:
Steel and glass.

Finish:
Satin Black
with Brushed
Brass accents.

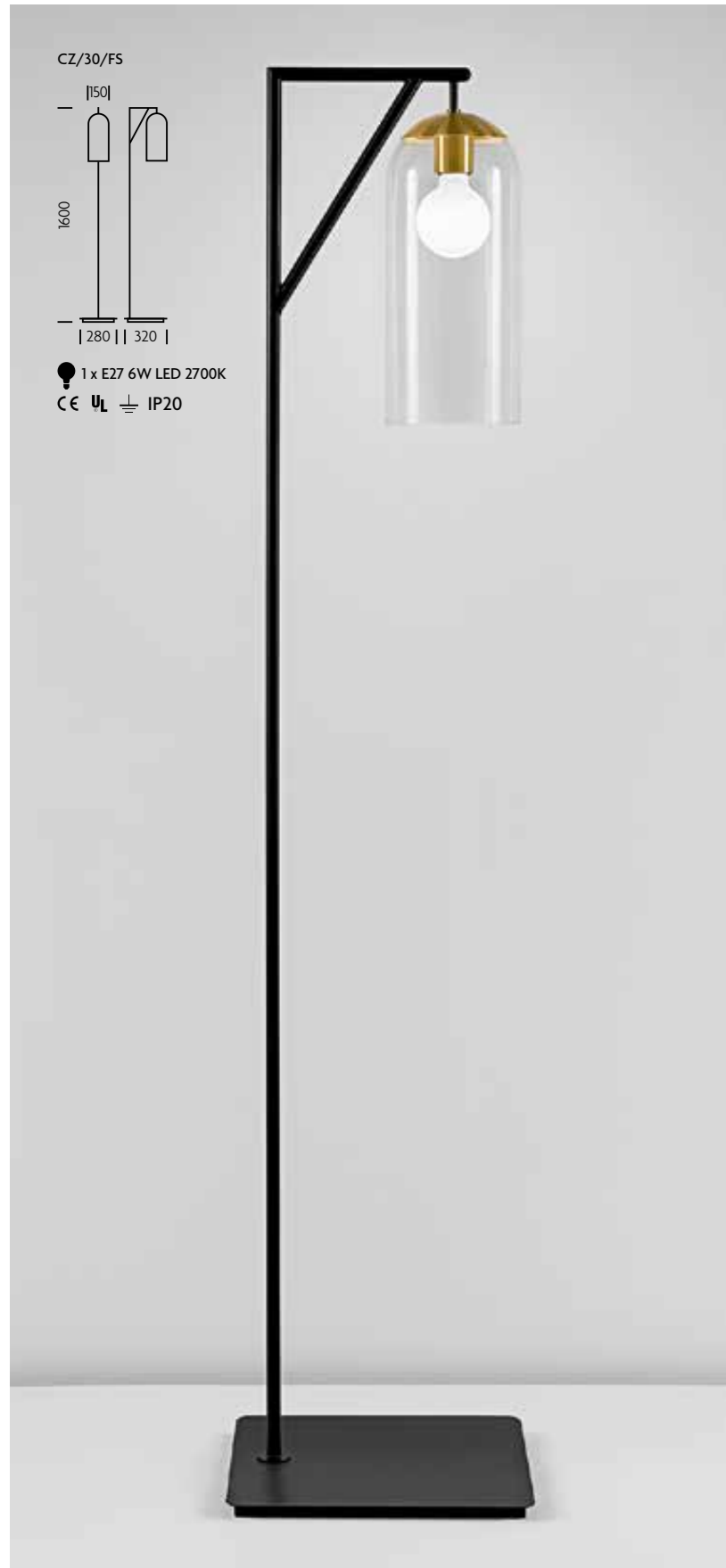

Copyright 2020 Chelsom Ltd

SYDNEY

Features: Asymmetric directional metal shades enclose warm white LED light sources. The stepped conical bases and wall light backplate house retro toggle switches. Wall light arms rotate left/right.

Material:
Steel.

Finish:
Satin Black with Golden Bronze (BL/GB).

SY/45/TL/BL/GB

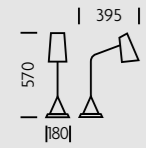

LED 6W 2700K
CE \equiv IP20
(For UL please enquire.)



SY/45/W1/BL/GB

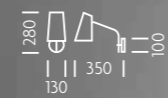

LED 6W 2700K
CE \equiv IP20
(For UL please enquire.)



PHONO

Features: Conical fabric shades fit seamlessly into spun metal cone holders. Table and floor lamps stand on heavy Satin Black cylindrical bases. Table and floor lamps stand on heavy Satin Black cylindrical bases.

Material:
Steel.

Finish:
Brushed Brass with Satin Black.

Shades:
Shades are bespoke with other fabric options available.

PH/05/W1 with optional shade QPH/7/NAT

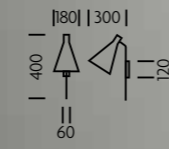

1 x E27 7W LED 2700K
CE \equiv IP20



PH/05/TL with optional shade QPH/7/NAT

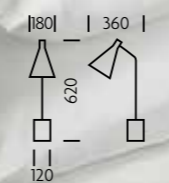

1 x E27 7W LED 2700K
CE \equiv IP20



PH/05/FS with optional shade QPH/11/NAT

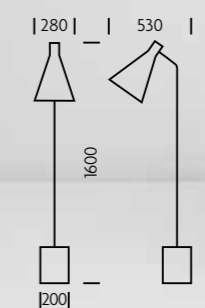

1 x E27 8W LED 2700K
CE \equiv IP20



Copyright 2020 Chelsom Ltd

BALTIMORE

Features: Angled upright columns and protruding arms support Opal glass globes which are secured with threaded metal rings to ensure safety and durability. High quality glass gives soft diffusion of light.

Materials:
Steel and glass.

Finish:
Brushed Brass with Opal glass.



BT/8/W1
 90
 250 | 290 |
 140
 200
 1 x E27 7W LED 2700K
 CE U L IP20



BT/8/TL
 200 | 400 |
 550
 150 | 200 |
 1 x E27 7W LED 2700K
 CE U L IP20

PEEP

Features: Tall tapered columns on chamfered edge bases pass through fabric shades which are angle cut at the bottom to project light forward.

Material:
Steel.

Finish:
Brushed Brass with Satin Black.

Shades:
Other fabric options available for these bespoke shades.



PP/12/W1 with optional shade QPP/W1/BG
 230 |
 575
 100
 200 |
 1 x E27 7W LED 2700K
 CE U L IP20



PP/12/FS with optional shade QPP/FS/BG
 300 | 300 |
 1600
 280 |
 1 x E27 8W LED 2700K
 CE U L IP20



PP/12/TL with optional shade QPP/TL/BG
 200 | 200 |
 600
 185 |
 1 x E27 7W LED 2700K
 CE U L IP20

Copyright 2020 Chelsom Ltd

RICHMOND

Features: Internal integral LED light sources allow very shallow shades for unique proportions and excellent diffused light distribution. The range is complete with off white fabric shades secured on top with decorative grooved discs. Table and floor lamps include dimmer switches (wall light dimmable remotely).

Materials:
Steel and fabric.

Finish:
Brushed Brass (BRB).



RI/23/FS/BRB
500
1450
1580
300
LED 8W 2700K
CE UL IP20
(For UL please enquire.)



RI/23/WI/BRB
250 | 310 |
195 | 200 |
LED 5W 2700K
CE UL IP20
(For UL please enquire.)



RI/23/TL/BRB
350 |
480 | 585 |
200 |
LED 6W 2700K
CE UL IP20
(For UL please enquire.)

SHADY

Features: A substantial wall light with cylindrical shade enclosed with Brushed Brass top and bottom caps. The chunky table lamp has metal banding top and bottom and an under base finished in Off White. See page 239 for alternative wall light fabric shade.

Material:
Steel.

Finish:
Brushed Brass with table lamp under base Off White.

Shades:
Shades are bespoke for this range. Other fabric options available.



SX/48/TL with optional shade QSX/TL/NAT
250 |
550 |
200 |
1 x E27 7W LED 2700K
CE UL IP20

SX/48/WI with optional shade QSX/WI/NAT
180 | 210 |
300 | 40 |
1 x E27 7W LED 2700K
CE UL IP20

CHICANE

Features: A collection featuring twin arms which curve upwards and downwards on opposite sides of a central column to give good up and down light.

Material:
Steel.

Finish:
Golden Bronze.



CROOK

Features: A stepped column supporting a shepherd's crook style arm allows a good spread of downlight. Table and floor lamp bases plus wall light backplate have a rounded stepped detail. Lampholder cover has knurled detailing.

Material:
Steel.

Finish: English Brass with Satin Black.



Copyright 2020 Chelsom Ltd

SOLEIL

Features: Handmade fabric shades sit within metal circles supported by columns and shallow conical bases.

Material:
Steel.

Finishes:
Brushed Brass (BRB)
or Satin Black (BL).

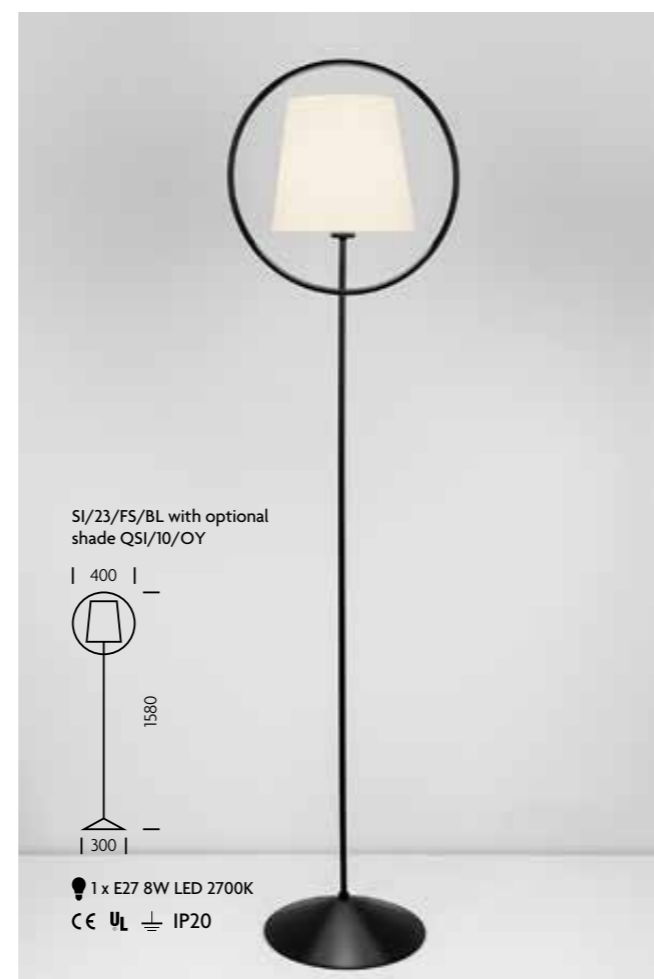

Copyright 2020 Chelsom Ltd

DIFFUSE

Features: Heavy moulded cross-hatched Clear glass diffuses the light into a warm ambient glow. Metalwork is soft Brushed Brass with Satin Black banding. **THE RANGE IS PRICED WITH AND COMES COMPLETE WITH LAMPS AS SHOWN.**

Materials:
Steel and glass.

Finish:
Brushed Brass with
Satin Black and
Clear glass.



DI/35/P

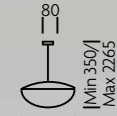

| 350 |

Weight 3.6kg

1 x E14 3W LED 2200K

CE U L IP20



DI/35/F

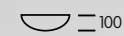

| 350 |

Weight 3.5kg

1 x E14 3W LED 2200K

CE U L IP20



DI/36/P

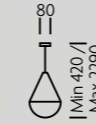

| 200 |

Weight 1.7kg

1 x E14 3W LED 2200K

CE U L IP20



DI/36/W1



| 200 | | 210 |

1 x E14 3W LED 2200K

CE U L IP20



Copyright 2020 Chelsom Ltd

SAUCER

Features: Shallow directional heads with Opal acrylic diffusers house warm white integral LED light. Wall and table lamps have integral toggle switches.

Materials:
Steel with acrylic diffuser.

Finish:
Satin Black with Brushed Brass (BL/BRB).



LUNAR Black

Features: Heavy stone bases and backplates sit within curved metal surrounds and glass globes are secured with threaded metal rings to ensure safety and durability. Wall lights can be fitted as up or down lights. **THE RANGE IN THIS FINISH OPTION IS PRICED WITH AND COMES COMPLETE WITH LAMPS AS SHOWN.**

Materials:
Steel, stone and glass.

Finishes:
Satin Black (BL) with Grey stone and Smoke glass. See following pages for alternative finish - Brushed Brass (BRB) with Natural stone and Opal glass.



LUNAR Brass

Features: Heavy stone bases and backplates sit within curved metal surrounds and glass globes are secured with threaded metal rings to ensure safety and durability. Wall lights can be fitted as up or down lights.

Materials:
Steel, stone and glass.

Finishes:
Brushed Brass (BRB) with Natural stone and matt Opal glass. See previous page for alternative finish - Satin Black (BL) with Grey stone and Smoke glass.



Copyright 2020 Chelsom Ltd

ROMA

Features: Tapered perforated metal shades with internal PVC Opal diffusers give a dramatic and softly diffused light effect. The table lamp has a directional shade and integral push switch in the base.

Material:
Steel.

Finish: Golden
Bronze with
Satin Black.



RM/9/F5

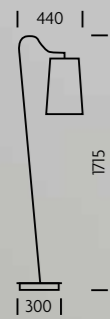

1 x E27 8W LED 2700K
CE U_L IP20



RM/9/P

1000



245

Weight 2kg
1 x E27 8W LED 2700K
CE U_L IP20



RM/9/W1

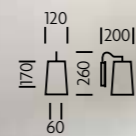

1 x E27 7W LED 2700K
CE U_L IP20



RM/9/TL



1 x E27 7W LED 2700K
CE U_L IP20

Copyright 2020 Chelsom Ltd

RADAR

Features: Shallow perforated metal coolie shades are supported by detailed knurled lampholder covers and contain LED squirrel cage filament lamps. RA/4/DL and RA/5/W1 have directional heads and the table lamp has a knurled rotary dimmer switch. RA/4/W1 can be ceiling mounted. **THE RANGE IS PRICED WITH AND COMES COMPLETE WITH LAMPS AS SHOWN.**

Material:
Steel.

Finish:
English Brass
with Satin Black.



ROCK

Features: Refined vertical and curved columns sit on square detailed plates and heavy natural stone cubes ensuring good stability.

Materials:
Steel with
natural stone.

Finish:
Black Bronze
metalwork with
Natural stone.



Copyright 2020 Chelsom Ltd

TOKYO

Features: Smoke seed glass globes enclose warm white LED filament lamps. The pendant has an optional Oyster fabric inner shade and is supplied with a fixed suspension rod which can divide into three connectable parts (250mm, 400mm or 600mm). **THE RANGE IS PRICED WITH AND COMES COMPLETE WITH LAMPS AS SHOWN.**

Materials:
Steel and glass.

Finish:
Brushed Brass and
Smoke seed glass.



Copyright 2020 Chelsom Ltd

CAPRI

Features: Heavily ribbed Opal glass shades are secured with metal threads onto knurled decorative double-stepped caps. Wall lights can be installed as up or downlighters. Light sources are integral, dimmable warm white LED. See page 296 for matching ceiling fittings.

Materials:
Steel and glass.

Finishes:
Brushed Brass (BRB) or Black Bronze (BB) with frosted Opal glass.



TRANQUILLO

Features: A collection featuring mouthblown heavy glass globes with an intricate 'snowflake' detail giving soft diffused light and delicate patterns onto Brushed Brass metalwork. The pendant is available in two sizes.

Materials:
Steel and glass.

Finish:
Brushed Brass with snowflake glass.



Copyright 2020 Chelsom Ltd

SHAFTESBURY

Features: A double arm design with wall and table options. All models have a central knurled section and the table lamp is operated by a rotary dimmer switch.

Material:
Steel.

Finish:
Black Bronze with
English Brass (BB/EBR).

SH/60/W2/BB/EBR with
optional shades QSH/6/BG

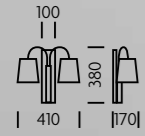

2 x E27 7W LED 2700K
CE U_L IP20



SH/60/W1/BB/EBR
with optional shade
QSH/6/BG

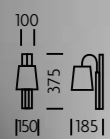

1 x E27 7W LED 2700K
CE U_L IP20



SH/60/TL2/BB/EBR
with optional shades
QSH/6/BG



2 x E27 7W LED 2700K
CE U_L IP20

Project: SHAFTESBURY at The Grand Hotel, Lytham St. Annes.
Designer: In-house Design Team.



Copyright 2020 Chelsom Ltd

BOSTON

Features: Stepped bases (with colour co-ordinated push switches on table lamps) support crossed columns with decorative end turnings.

Material:
Steel.

Finishes:
Black Bronze with English Brass (BB/EBR) or Polished Chrome (C).

Shades:
Other fabric options available for these bespoke shades.



BO/22/FS/BB/EBR with optional shade Q22/FS/BG

1665

300 | 670 |

1 x E27 8W LED 2700K
CE U L IP20



BO/22/W1/BB/EBR with optional shade Q22/W1/BG

150

200 | 240 |

1 x E27 7W LED 2700K
CE U L IP20



BO/22/W1/C with optional shade Q22/W1/GM



Project: BOSTON at Abode Glasgow.
Designer: 10 Design.



BO/22/TL/BB/EBR with optional shade Q22/TL/ST

660

200 | 400 |

1 x E27 7W LED 2700K
CE U L IP20



BO/22/TL/C with optional shade Q22/TL/IVPL

Copyright 2020 Chelsom Ltd

Project: PIAZZA at Párisi Udvar Hotel Budapest.
Designer: KROKI STUDIO.

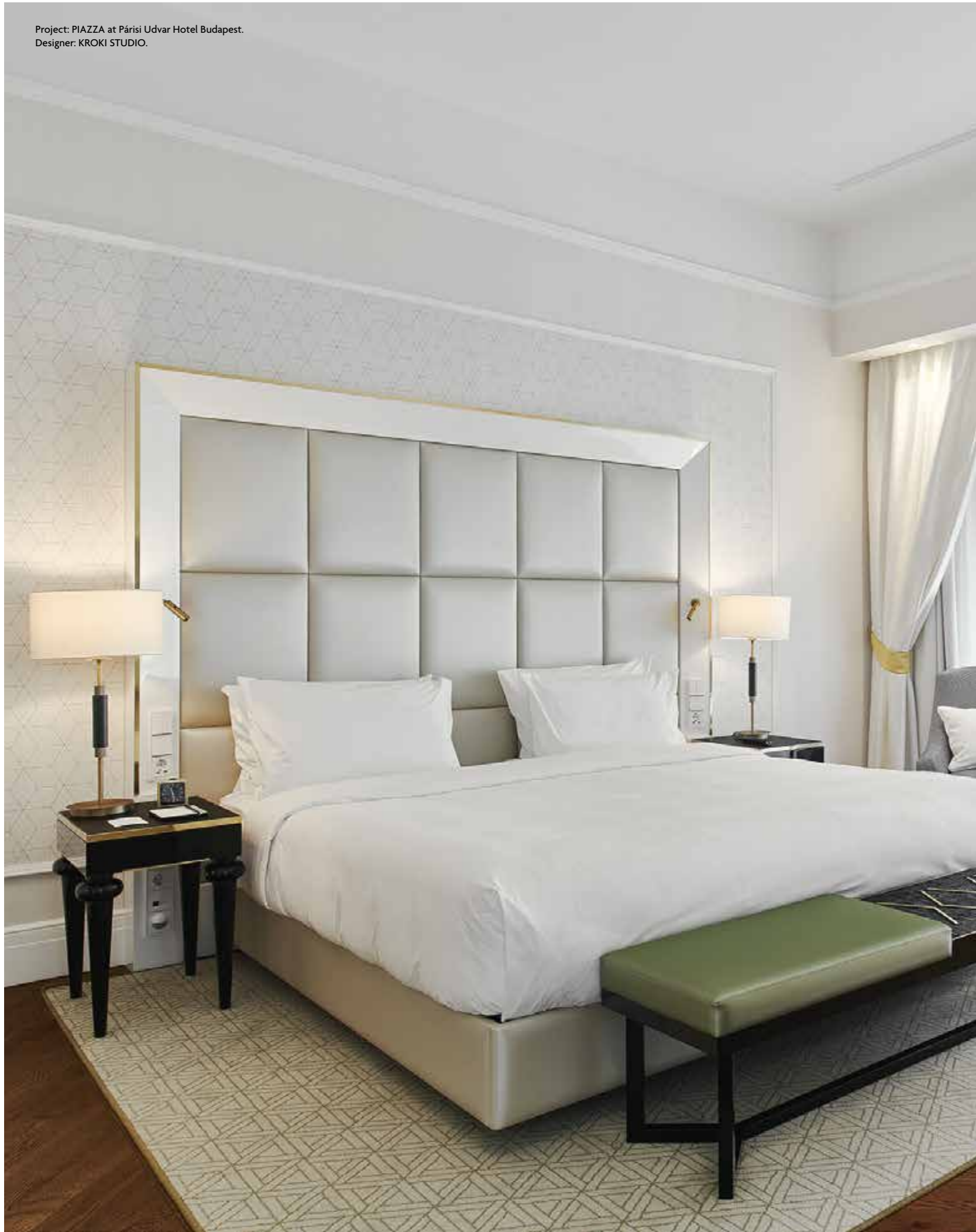

PIAZZA

Features: Chunky Ebony stained wooden sections combine with reeded tubing to feature in this elegant guestroom lighting design.

Materials:
Steel and wood.

Finish:
Golden Bronze
with Ebony.



CHICAGO

Features: A Deco inspired collection featuring rectangular section tube which joins the circular base or backplate with a stepped detail. Shallow bespoke shades with bottom fabric diffusers (except Black with Gold lining) and integral LED light sources are supported from above and surround Opal acrylic top diffusers. Other shade fabrics available.

Materials:
Steel with acrylic diffuser.

Finish:
Black Bronze with English Brass (BB/EBR).



CHECK IN Chrome

Features: Rounded rectangular shades are enclosed within twin upright square section columns. Wall light is also available with LED reading light and switch on the backplate.

Material:
Steel.

Finishes:
Polished Chrome (C) with Black underbase. See page 86 for Brushed Brass (BRB) finish

Shades:
All shades are bespoke for the Check In range. Fabrics shown are Oyster cottonette (OY) and Natural (NAT). Other fabrics to special order. Shades have integral top diffusers with a central ventilation hole.



Copyright 2020 Chelsom Ltd



CHECK IN Brass

Features: Slim rounded corner rectangular shades are held within the rectangular metal framework of the double columns.

Material: Steel.

Finishes: Brushed Brass (BRB) with black underbase. See previous pages for Chrome (C) finish.

Shades: Shades are bespoke for the Check In range. Fabrics shown are Natural (NAT) with other fabrics to special order. Shades have integral top diffusers.

CH/9/TL/BRB with optional shade QCHB/14/NAT

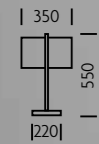

1 x E27 7W LED 2700K
CE UL IP20



CH/9/W1/LED/BRB with optional shade QCHB/14/NAT

1 x E27 7W LED 2700K plus 1 x LED 1W 2700K
CE UL IP20

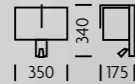

PARK

Features: Sleek swivel arm action allows 270° rotation or shade can be 'parked' within the top framework. Shades have detailed Opal acrylic top diffuser. Neat when 'parked', the shades give a wide arc of light when extended. For floor and table, the cable exits above the slim flat bases.

Materials: Steel with acrylic diffuser.

Finish: Black Bronze (BB).

PK/16/TL/BB with optional shade QPK/12/OY

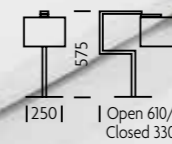

1 x E27 7W LED 2700K
CE UL IP20



PK/16/F5/BB with optional shade QPK/16/OY

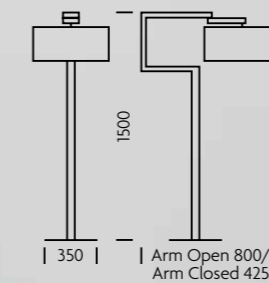

1 x E27 8W LED 2700K
CE UL IP20

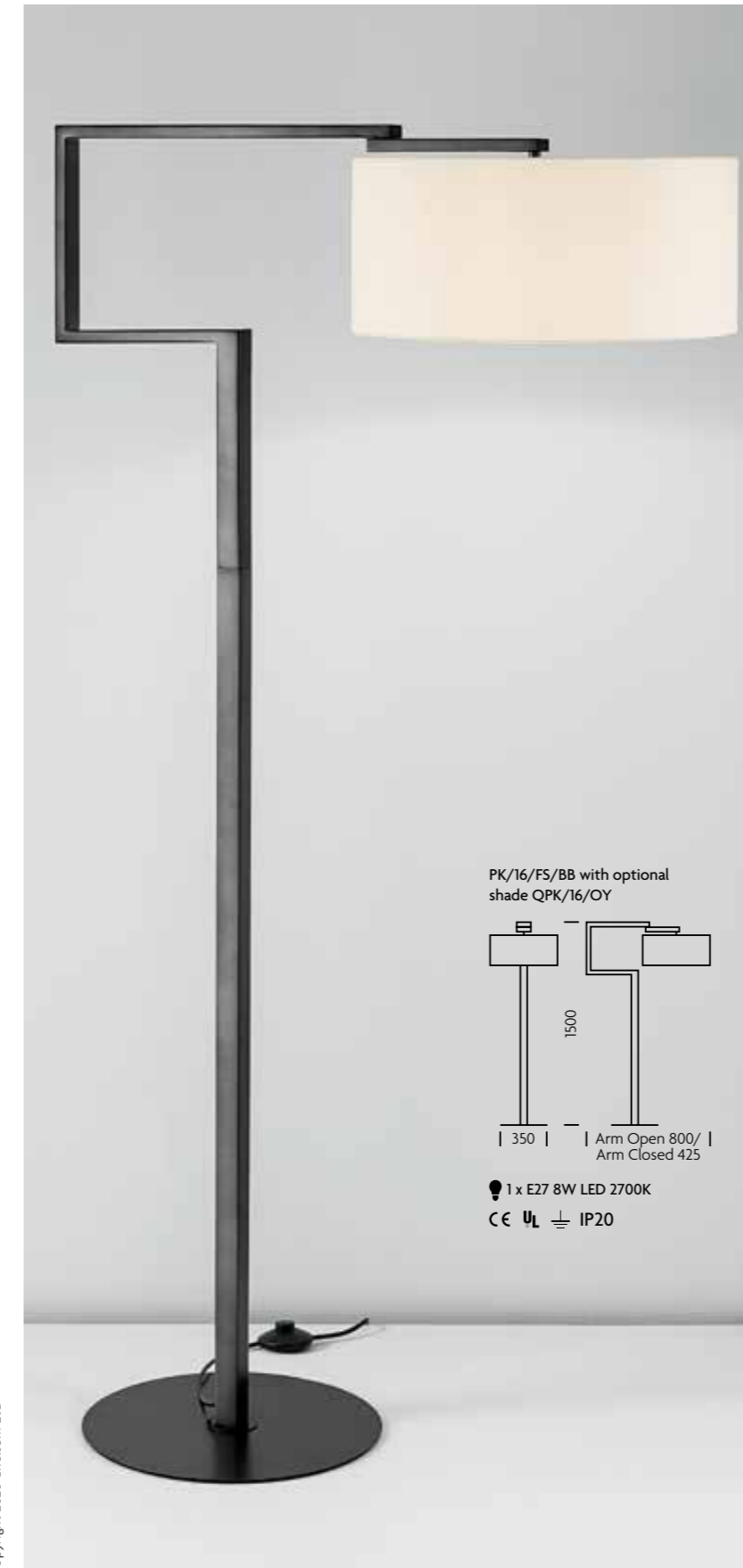

PK/16/W1/BB with optional shade QPK/10/OY



1 x E27 7W LED 2700K
CE UL IP20



Copyright 2020 Chelsom Ltd

SWING Reading

Features: Robust detailed hinges allow arms to swivel. Cylindrical heads with ventilation hole rotate to give directional reading light.

Material:
Steel.

Finishes:
Polished Chrome (C)
or Black Bronze (BB).



Copyright 2020 Chelsom Ltd

SWING Brass

Features: Robust detailed hinges allow arms to swivel.

Material:
Steel.

Finish:
Antique Brass (AB).

Shades:
See back of catalogue for full range of optional shades.



SW/39/FS/AB with optional shade QST/18/LINEN BONE

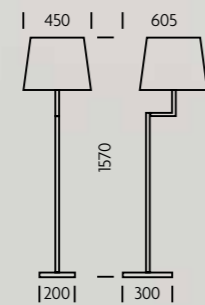

1 x E27 8W LED 2700K
CE U_L IP20



SW/39/TL/AB with optional shade QST/12/LINEN NAT

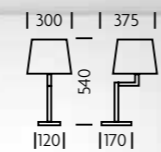

1 x E27 7W LED 2700K
CE U_L IP20



SW/39/W1/AB with optional shade QFD/8/LINEN NAT

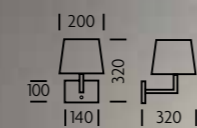

1 x E27 7W LED 2700K
CE U_L IP20

SWING Chrome

Features: Robust detailed hinges allow arms to swivel.

Material:
Steel.

Finish:
Polished Chrome (C).

Shades:
See back of catalogue for full range of optional shades.



SW/39/TL/C with optional shade QST/12/ST

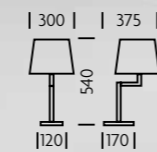

1 x E27 7W LED 2700K
CE U_L IP20



SW/39/W1/C with optional shade QFD/8/ST

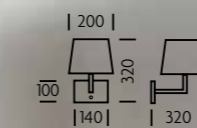

1 x E27 7W LED 2700K
CE U_L IP20



SW/39/FS/C with optional shade QST/18/ST

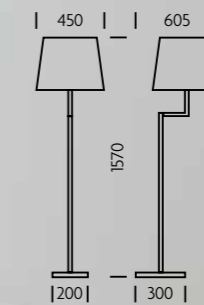

1 x E27 8W LED 2700K
CE U_L IP20

Copyright 2020 Chelsom Ltd

BOX

Features: Linear steel frames encase cylinder shades in a variety of fabrics. Pendant normally supplied with clear cable suspension. Fixed rod suspension for bedside use as shown to special order. Fixed rod suspension for bedside use as shown to special order.

Material:
Steel.

Finish:
Textured Black.

Shades:
Diffusers are fitted in the top and floor lamp shades and bottom of pendant shade. Other fabrics available to special order.



BX/44/TL with optional shade QBX/TL/NAT



1 x E27 7W LED 2700K
CE IP20
(For UL please enquire.)

Copyright 2020 Chelsom Ltd



CROSSOVER

Features: Crossover sections pass one in front of the other (except wall light) and wooden bases are mounted on protective Chrome plinths.

Materials:
Steel and wood.

Finish:
Polished Chrome
with Chocolate
wood bases.

Shades:
See back of catalogue
for full range of
optional shades.

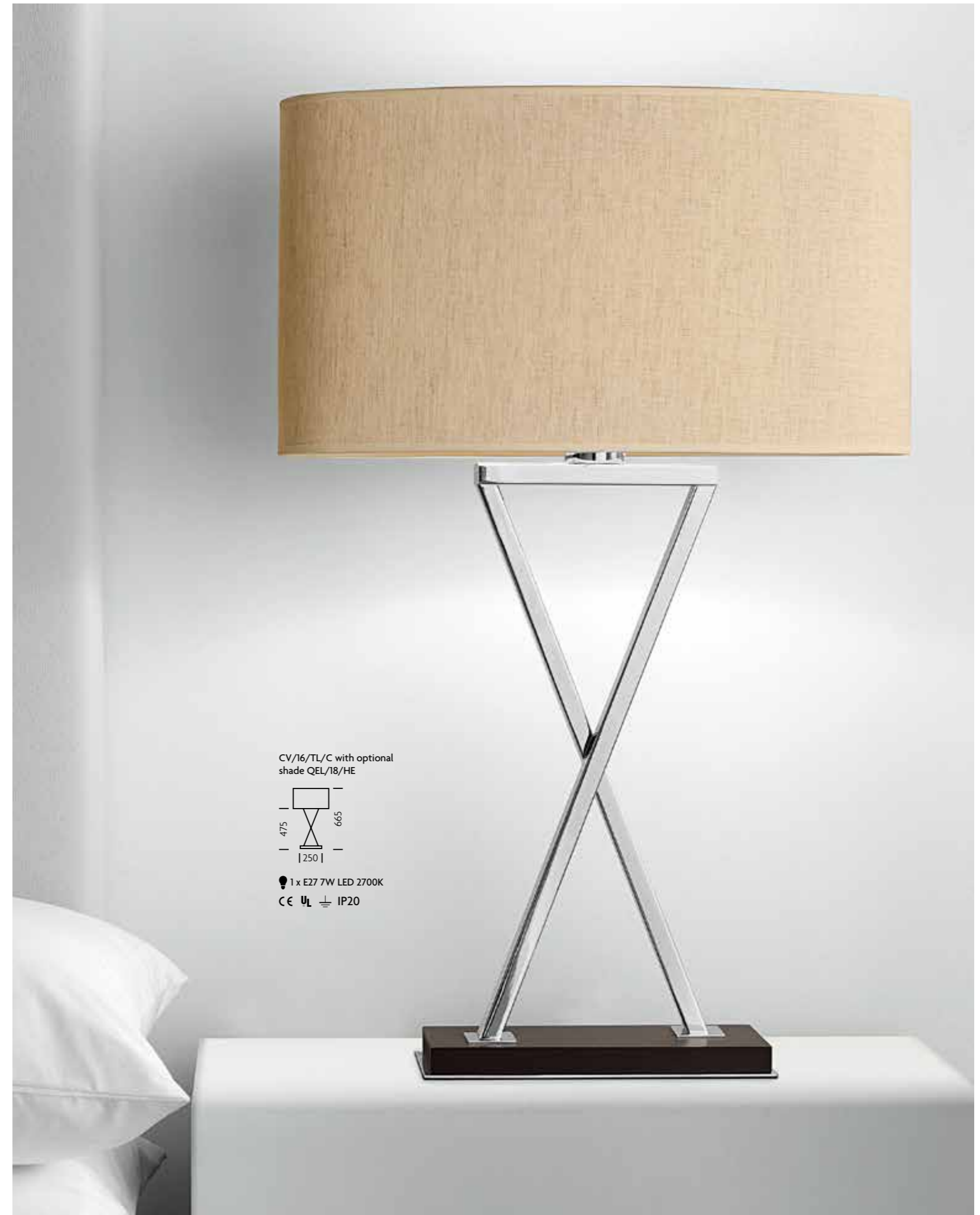
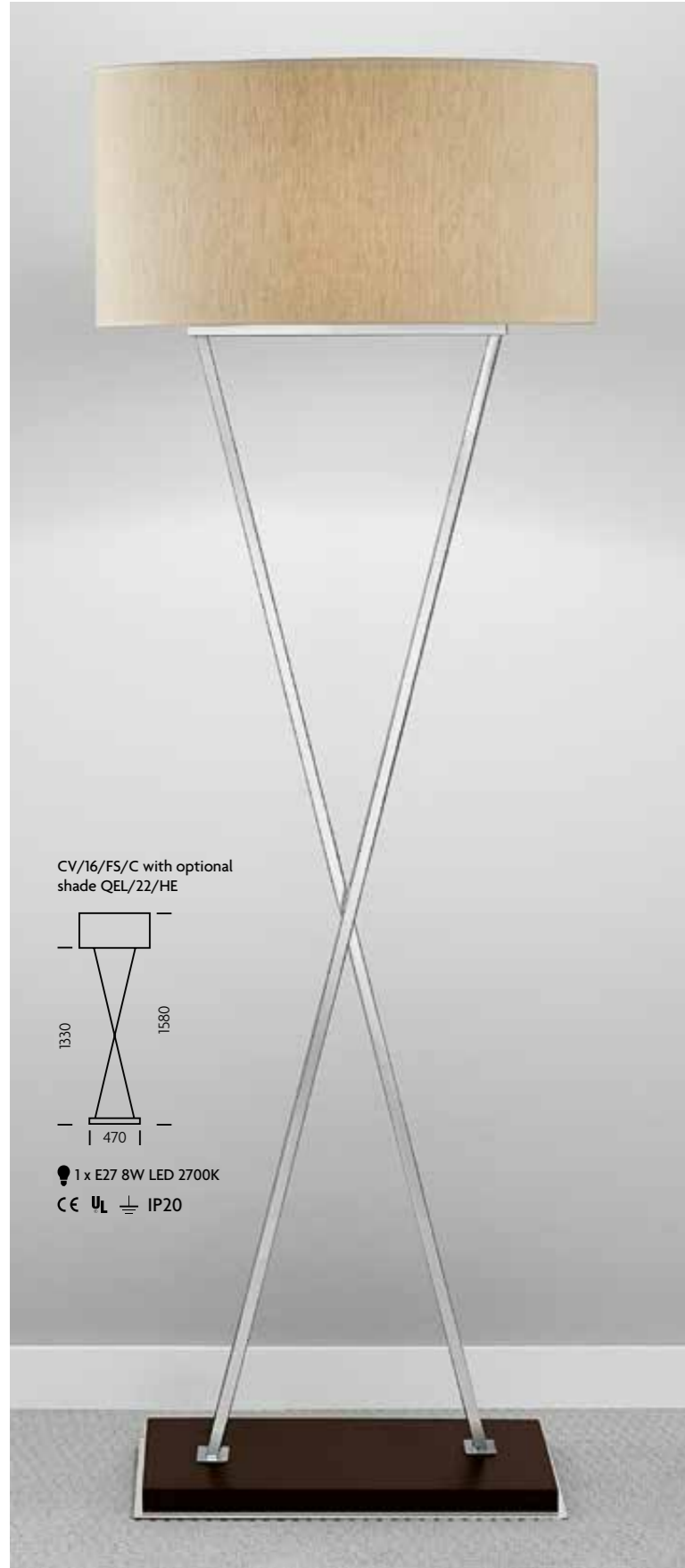

EXEC

Features: Oval hollow bases and tapered columns. Desk and table lamps have colour co-ordinated push switches in base. Floor lamps have vertical (FS1) or angled (FS2) columns.

Material:
Steel.

Finishes:
Polished Chrome (C), Black Bronze (BB) to special order for minimum quantities.

Shades:
All shades are bespoke for the Exec range. Desk and table lamps have a top diffuser with oval ventilation hole.



EX/5/FS1/C with optional shade QEX/FS1/NAT

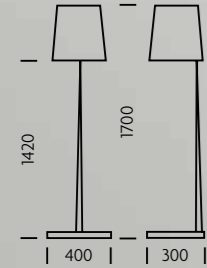

1 x E27 8W LED 2700K
CE U_L IP20

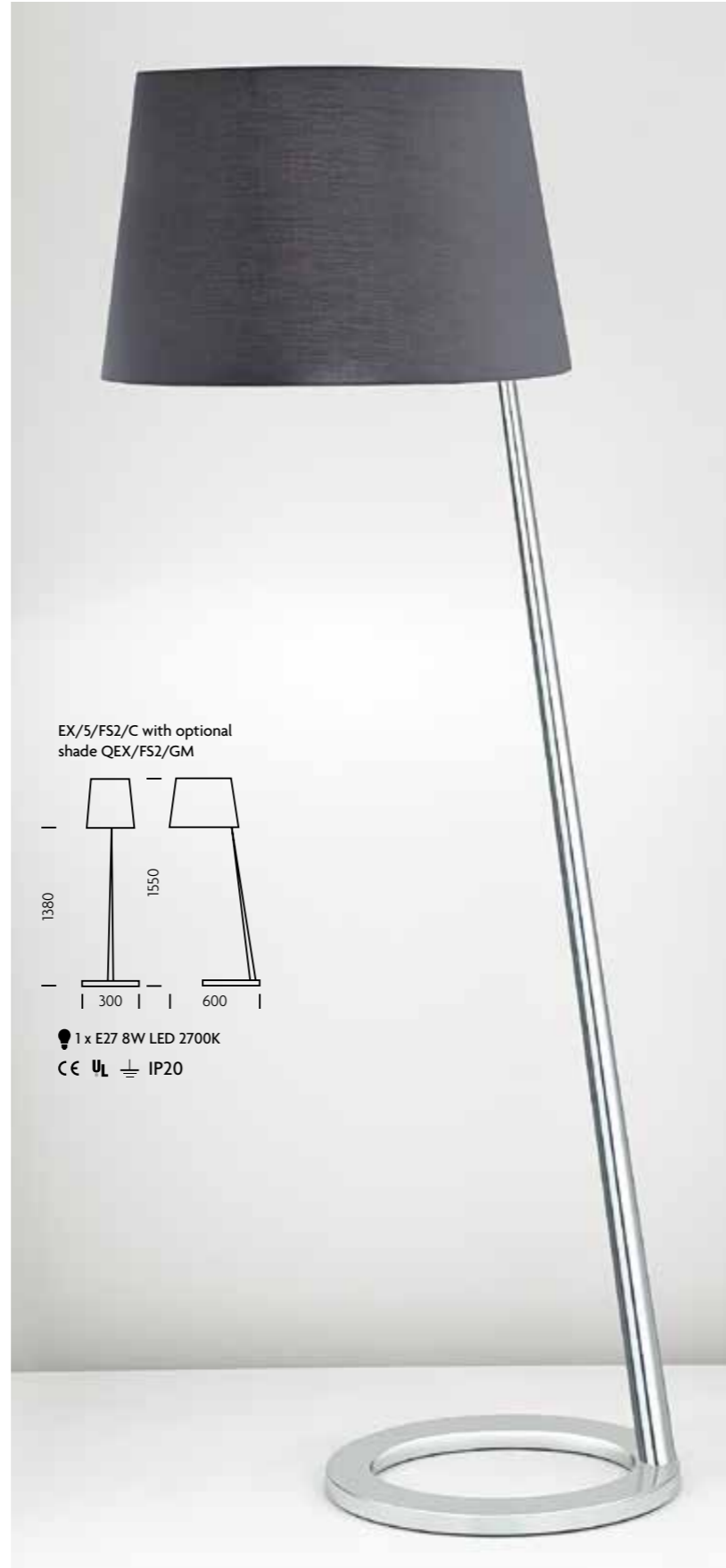

EX/5/FS2/C with optional shade QEX/FS2/GM

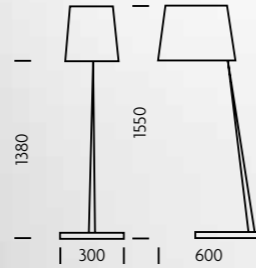

1 x E27 8W LED 2700K
CE U_L IP20



EX/5/DL/BB (custom finish) with optional shade QEX/DL/HE

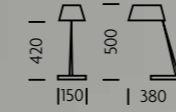

1 x E27 7W LED 2700K
CE U_L IP20



EX/5/TL/C with optional shade QEX/TL/NAT



1 x E27 7W LED 2700K
CE U_L IP20

Copyright 2020 Chelsom Ltd

TOWNHOUSE

Features: Rectangular stepped bases, tubular columns and triangular canopies give a timeless style. Upright columns swivel left/right and canopies rotate to give a full range of directional light. Desk and wall lights have knurled rotary dimmer switches. Canopies have internal polished metal reflectors.

Material:
Steel.

Finishes:
English Brass (EBR) or Black Bronze (BB).



Copyright 2020 Chelsom Ltd

TRIP

Features: TR/4/WI/LED/* has an integral driver and two switches, one for the main light and one for the LED reading light. Different switching options are available to special order for minimum order quantities of 50 pieces. **PRICING AND DIMENSIONS INCLUDE COTTON FABRIC SHADES (SPECIAL FABRICS MAY BE EXTRA).**

Material:
Steel.

Finishes:
Aluminium (AL)
or Champagne
Gold (CHG).

Shades:
Shades are bespoke for the Trip range and have integral top parchment diffusers. Other fabric options available - see back of catalogue.

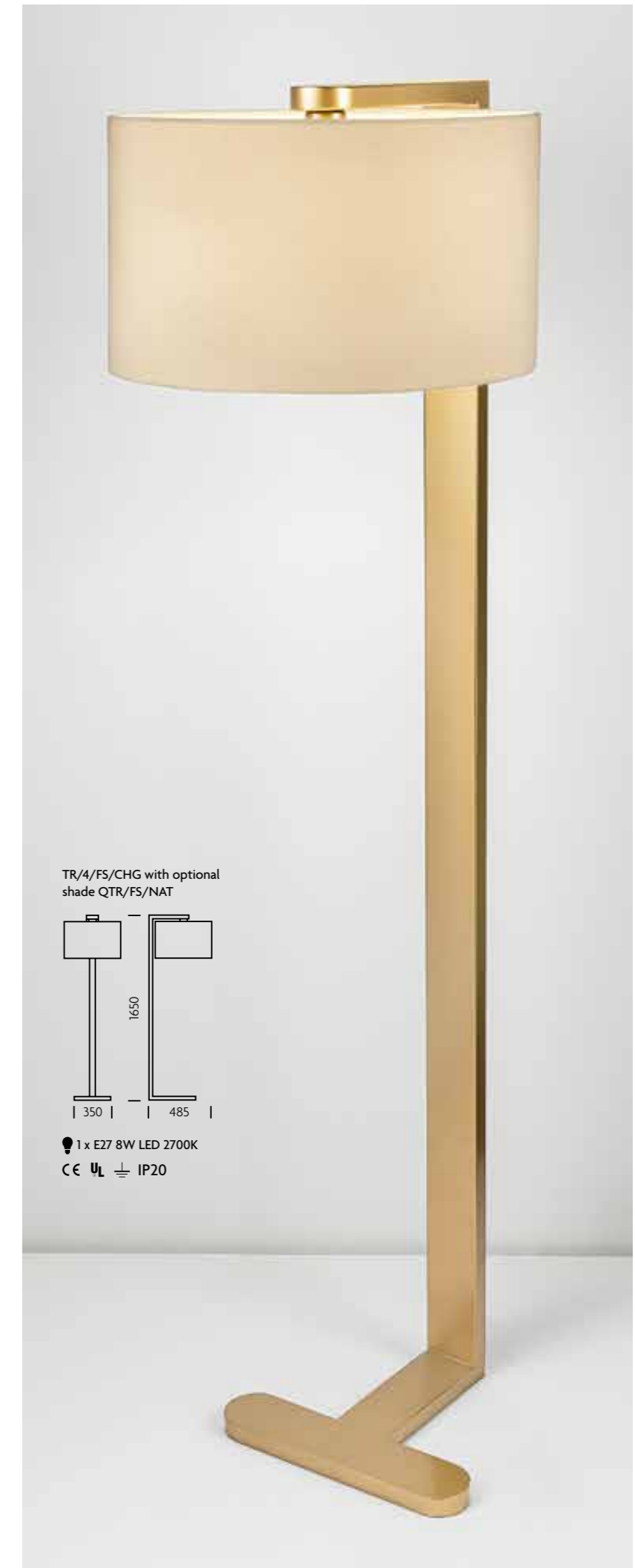

Copyright 2020 Chelsom Ltd

CITY

Features: An up-and-over arm configuration which suspends the shade at the top and runs across a slim base at the bottom. Tube ends have a rounded detail and fittings are complete with integral Opal acrylic top diffuser.

Materials:
Steel and acrylic diffuser.

Finishes:
Brushed Brass (BRB),
Brushed Nickel (BN)
or Satin Black (BL).

Shades:
Shades are bespoke for
this range with other
fabric options available.



POINT

Features: A directional table and floor lamp with robust arms finishing in a knurled handle allowing the light source to rotate. Wall light arm is fixed.

Material:
Steel.

Finishes:
Brushed Brass (BRB),
Brushed Nickel (BN),
or Satin Black (BL).

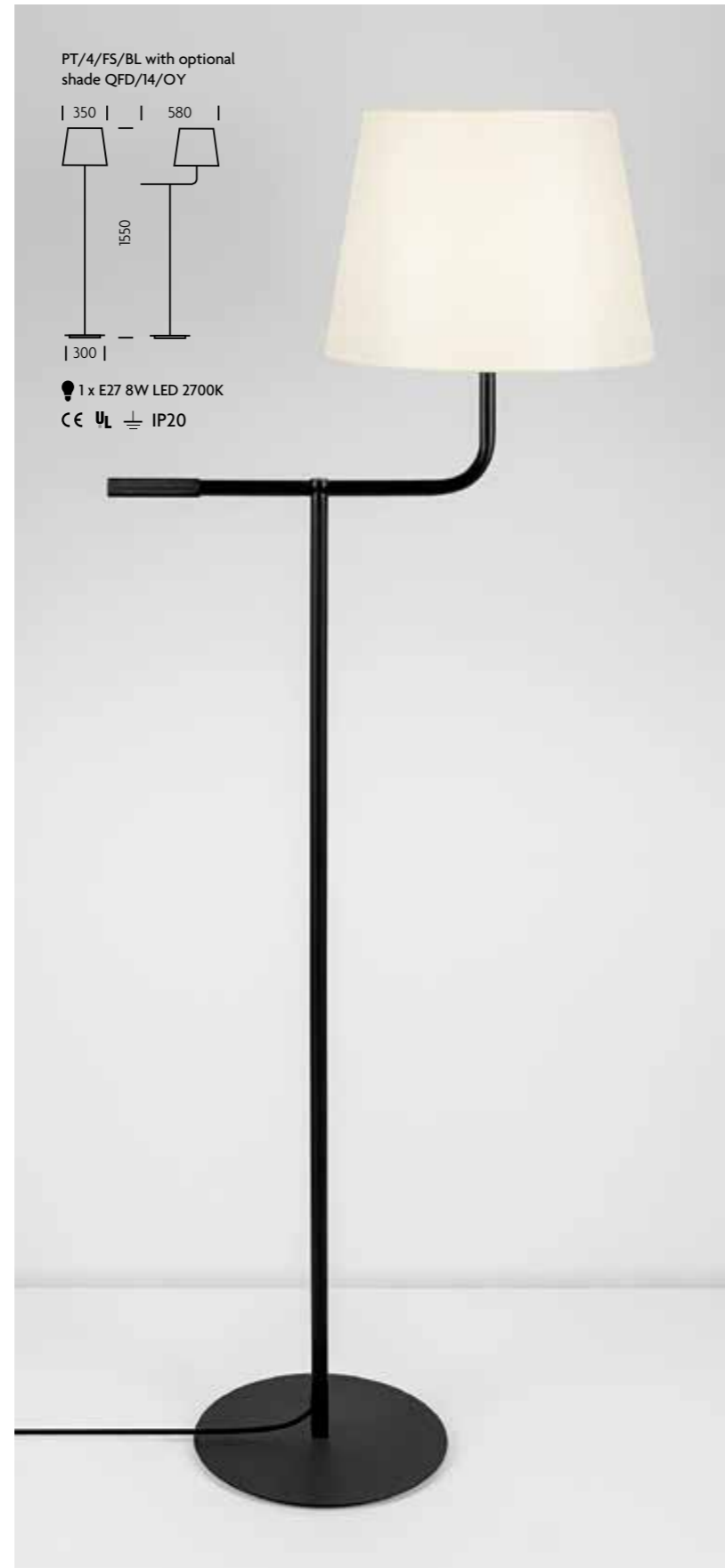

SLENDER



Features: Tall slender columns have faux grained wood centre sections. Tall cylinder shades are available in a range of fabrics.



Material:
Steel.

Finish:
Brushed Brass with faux grained wood.

CONE



Features: The conical metal head runs seamlessly into the conical fabric shade and gives soft diffused downlight. All heads swivel up/down and left/right. Arm to column joint is fixed.

Material:
Steel.

Finish:
Satin Black with Golden Bronze.

Shades:
Shades are bespoke for the range. Other fabric options available.

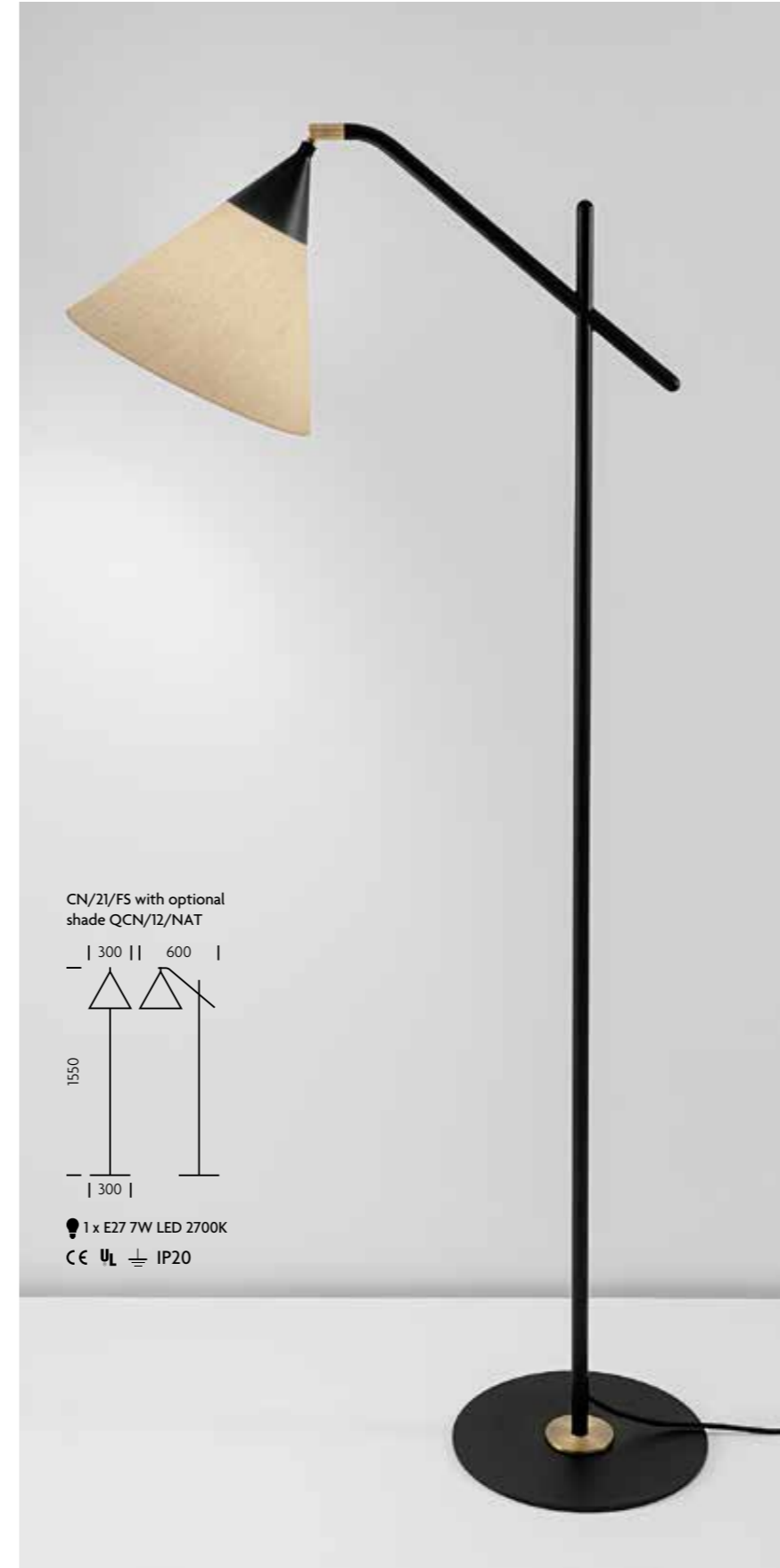

Copyright 2020 Chelsom Ltd

ANGLE



Features: Arms can be adjusted vertically with the shade always remaining upright.
Wall light swivels left – right. **PRICES AND DIMENSIONS INCLUDE SHADES SHOWN.**

Material:
Steel.

Finishes:
Polished Chrome (C) or Brushed Nickel (BN) with Oyster shades.

Shades:
See back of catalogue for full range of optional shades.

AL/52/DL/C
complete with shade

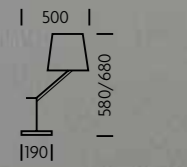

1 x E27 7W LED 2700K
CE UL IP20



Project: ANGLE at Grandhotel Brussels.
Designer: Bost Group.

AL/52/FS/C complete with shade

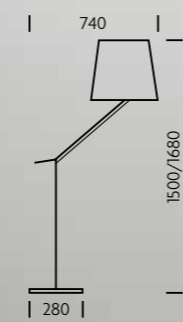

1 x E27 8W LED 2700K
CE UL IP20



AL/52/W1/BN
complete with shade

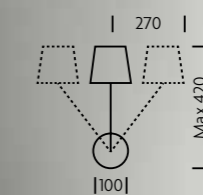

1 x E27 7W LED 2700K
CE UL IP20



Copyright 2020 Chelsom Ltd

DOWNTOWN

Features: Brushed Brass accents contrast with Satin Black metalwork and tapered shades are suspended giving good downlight. The table and floor lamps sit on heavy slim bases and the combination wall light has a directional switched LED reading light with integral driver in the backplate. Fabric shades are bespoke for this range - other fabrics available.

Material:
Steel.

Finish:
Satin Black with
Brushed Brass.



DW/6/FS with optional shade QDW/10/NAT

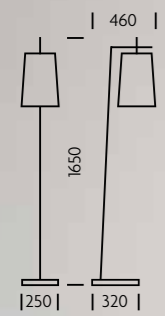

1 x E27 8W LED 2700K
CE U_L IP20



DW/6/W1 with optional shade QDW/5/NAT

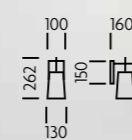

1 x E27 7W LED 2700K
CE U_L IP20



DW/6/TL with optional shade QDW/5/NAT

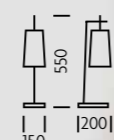

1 x E27 7W LED 2700K
CE U_L IP20

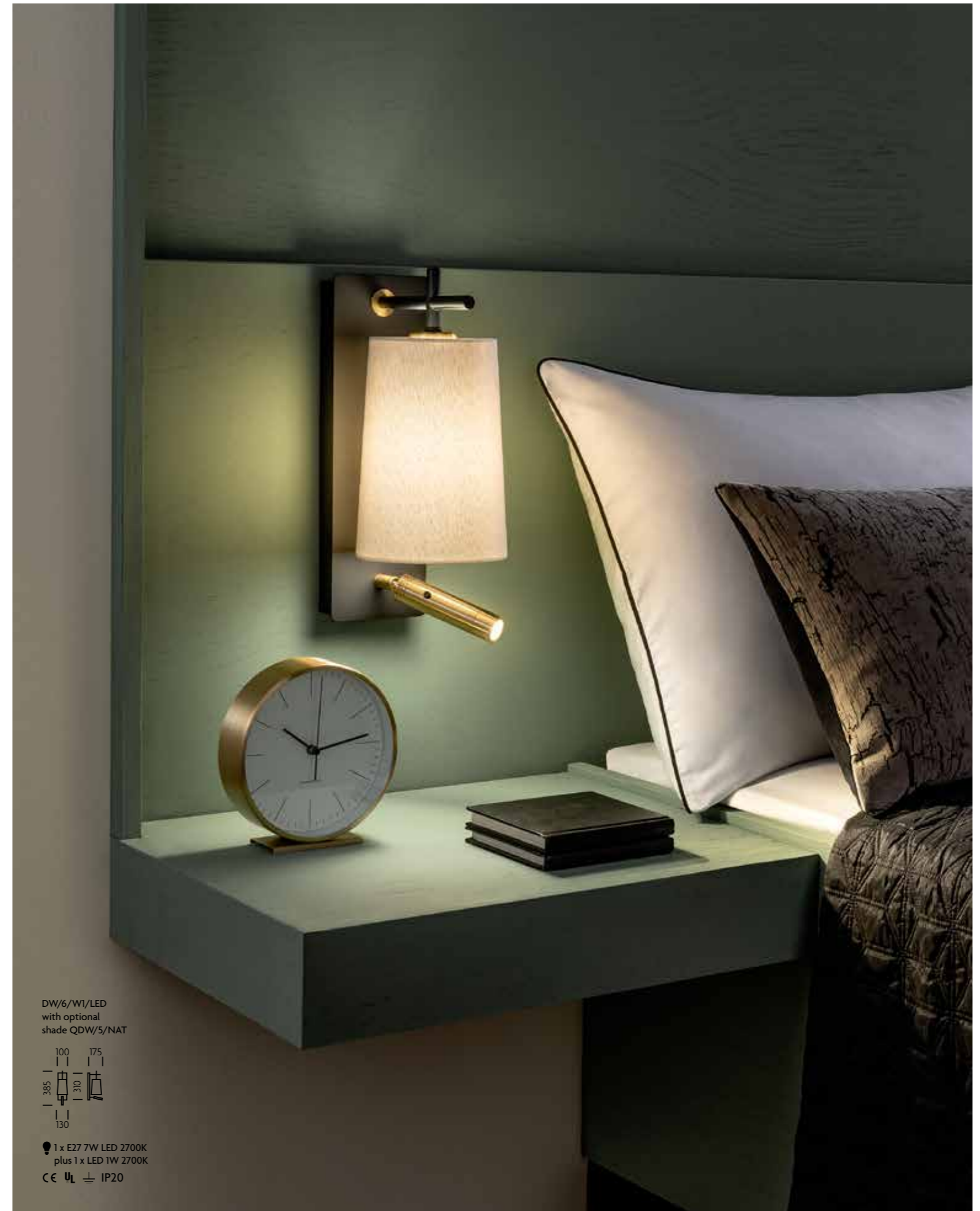

DW/6/W1/LED with optional shade QDW/5/NAT

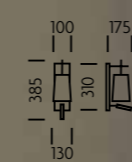

1 x E27 7W LED 2700K
plus 1 x LED 1W 2700K
CE U_L IP20

Copyright 2020 Chelsom Ltd

PLAZA



Features: A double column or arm feature joins rectangular bases or backplate.

Material:
Steel.

Finish:
Brushed Nickel.

Shades:
See back of catalogue for full range of optional shades.



PZ/4/FS with optional shade QEL/20/OY

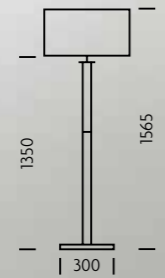

1 x E27 8W LED 2700K
CE U_L IP20



PZ/4/W1 with optional shade QEL/10/OY

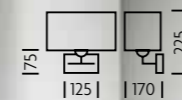

1 x E27 7W LED 2700K
CE U_L IP20



PZ/4/TL with optional shade QEL/16/OY

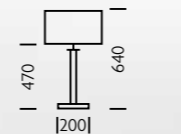

1 x E27 7W LED 2700K
CE U_L IP20

WEEKEND



Features: Off centre columns for table and floor lamps sit on heavy circular bases and the range has contrasting Walnut wood sections.

Materials:
Steel and wood.

Finish:
Satin Black with Walnut.



WK/70/W1 with optional shade QCY/6/E27/NAT

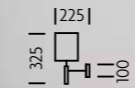

1 x E27 7W LED 2700K
CE U_L IP20



WK/70/TL with optional shade QCY/12/NAT

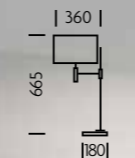

1 x E27 7W LED 2700K
CE U_L IP20



WK/70/FS with optional shade QCY/18/NAT

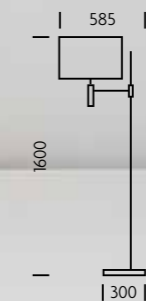

1 x E27 8W LED 2700K
CE U_L IP20

AVENUE

Features: Conical turnings join bases or backplate to columns or arm.
Floor lamp column is stepped.

Material:
Steel.

Finishes:
Polished Chrome (C) or
Satin Black with Brushed
Brass (BL/BRB).

Shades:
See back of catalogue
for full range of
optional shades.

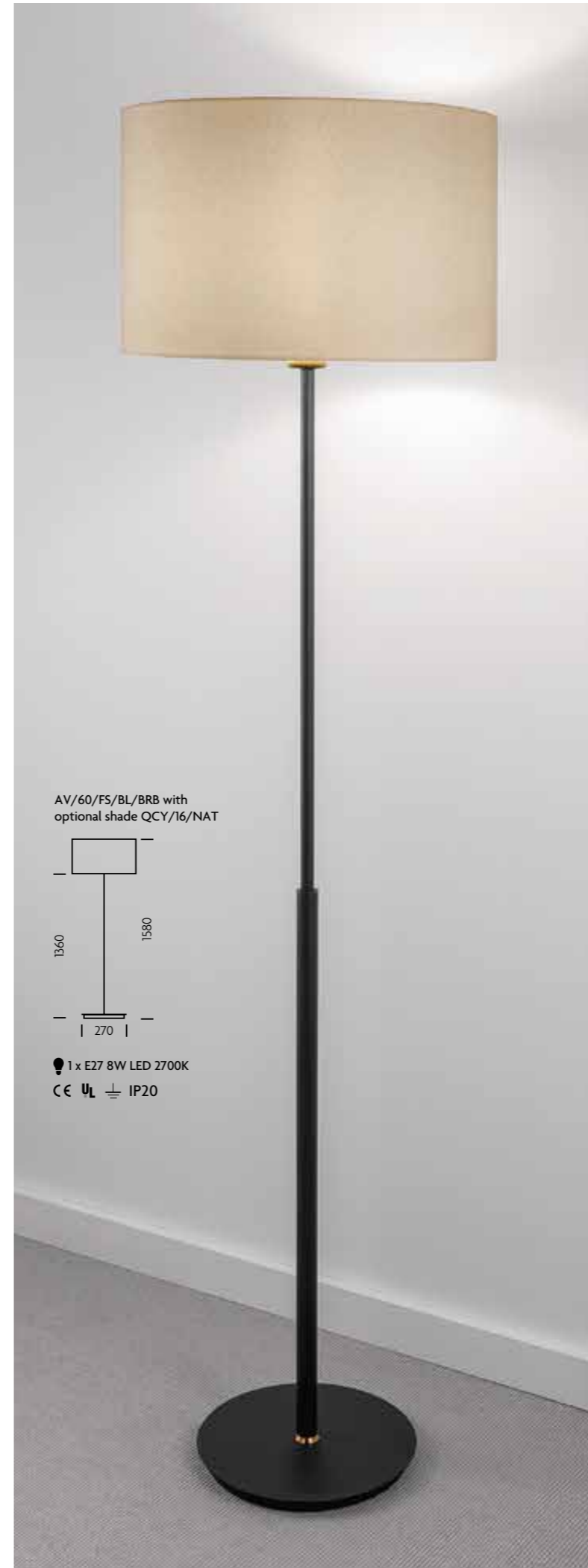

PROJECT

Features: Desk lamp and wall reading light have adjustable swivelling heads and wall reading light arm moves left – right. PJ/9/TL/LED/C has adjustable LED reading light with integral driver and two switches in the base.

Material:
Steel.

Finish:
Polished Chrome.

Shades:
See back of catalogue pages for full range of optional shades.

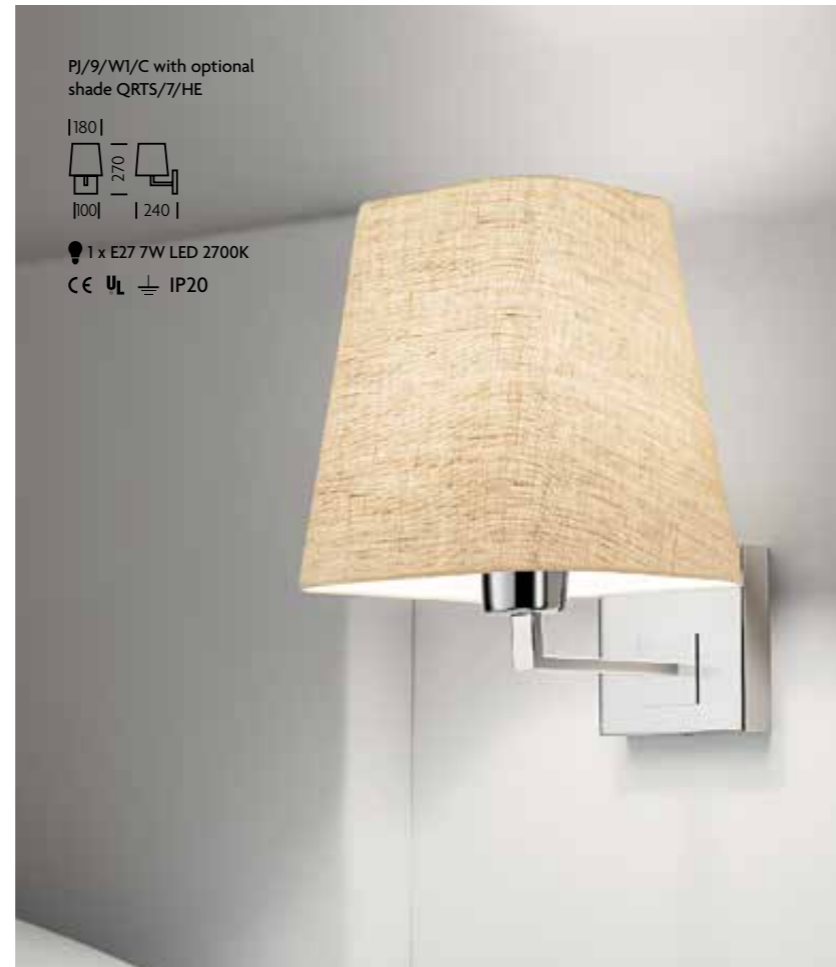

Copyright 2020 Chelsom Ltd

INTERIORS

Features: Round Polished Chrome plates are inset flush into square bases and backplates. Combination wall light has integral driver.

Material:
Steel.

Finish:
A combination finish of Brushed Nickel with Polished Chrome (BNC).

Shades:
See back of catalogue for full range of optional shades.



URBAN Brass



Features: Wooden bases are mounted on protective Brass metal plinths.
Combination LED wall light includes integral driver and reading light switch.

Materials:
Steel and wood.

Finishes:
Brushed Brass with Ebony (BRB/EB) - see following page for Polished Chrome with Chocolate wood (C/CH).

Shades:
Shades shown are bowed rectangles (QBR). See back of catalogue for full range of optional shades.

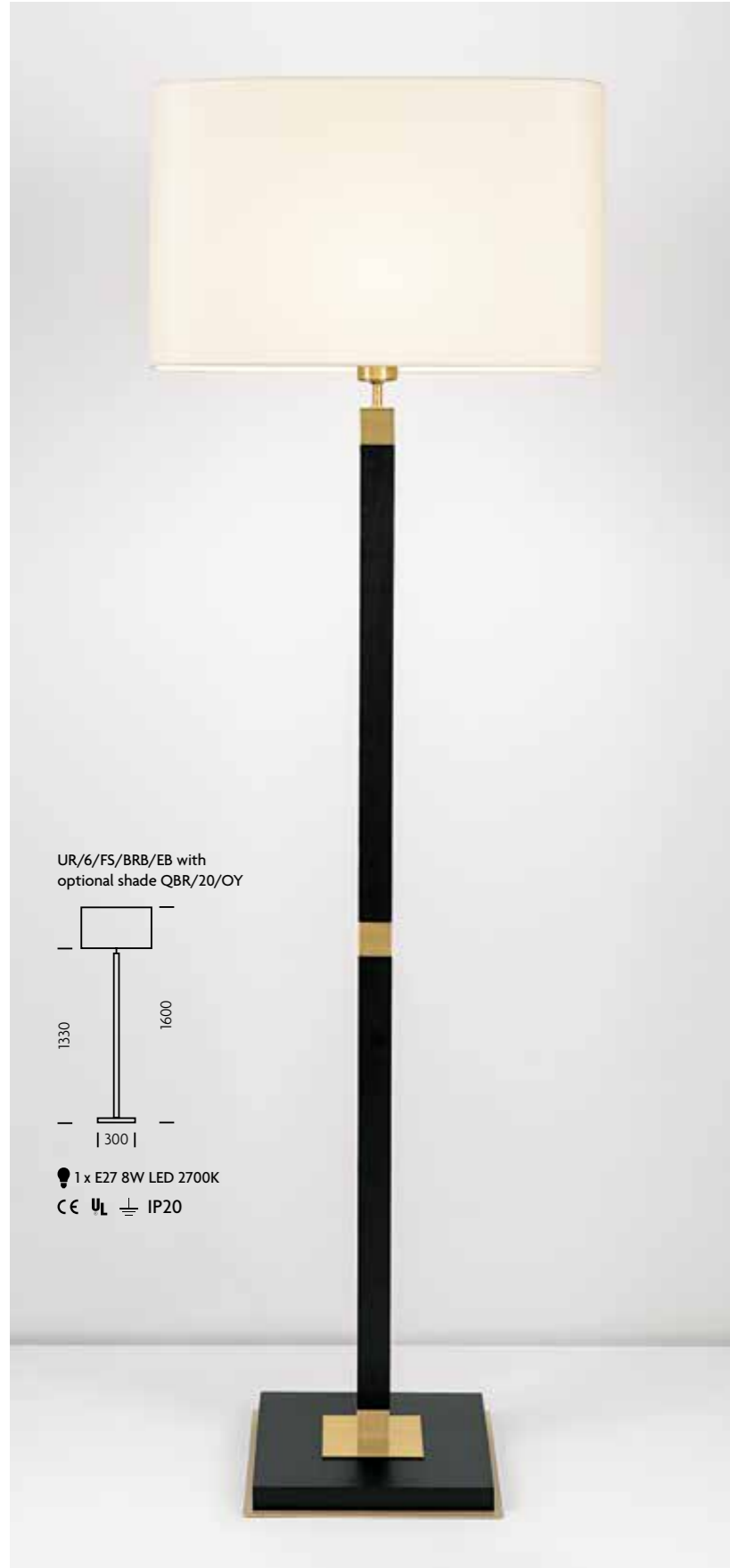

URBAN Chrome



Features: Wooden bases are mounted on protective Chrome plinths. Combination LED wall light includes integral driver and reading light switch.

Materials:
Steel and wood.

Finishes:
Polished Chrome and Chocolate Wood (C/CH). See previous pages for Brushed Brass with Ebony Wood (BRB/EB).

Shades:
Shades shown are bowed rectangles (QBR). See back of catalogue for full range of optional shades.



UR/6/FS/C/CH with optional shade QBR/20/W

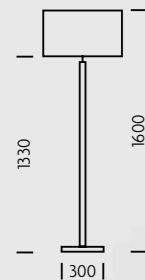

1 x E27 8W LED 2700K
CE U_L IP20

UR/6/TL/C/CH with optional shade QBR/16/W

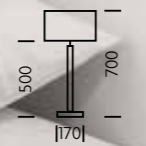

1 x E27 7W LED 2700K
CE U_L IP20



UR/6/W1/LED/C/CH with optional shade QBR/12/W

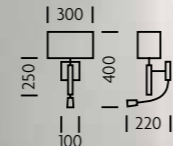

1 x E27 7W LED 2700K plus 1 x LED 1W 2700K
CE U_L IP20



UR/6/W1/C/CH with optional shade QBR/10/W

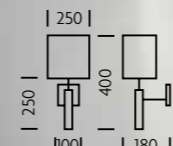

1 x E27 7W LED 2700K
CE U_L IP20

READING



READING



The Chelsom Value Award is given to ranges which represent exceptional value alongside high design and quality standards.



LED Eye 126



LED Eye 126



LED Dock Knurl 129



LED Focus VA 138



LED Focus VA 139



LED Classic 140



LED Dock 130



LED Dock 131



LED Dock 132



LED Dome 141



LED Reading VA 142



LED Reading VA 142



LED Dock Combi 134



LED Dock Combi 135



LED Knurl 136



LED Reading VA 142



LED Reading VA 143



LED Reading VA 143

Copyright 2020 Chelsom Ltd

LED EYE

Features: A discreet LED bedside reading light which recesses into the headboard leaving it almost entirely flush to the surface. The unique lip feature at the bottom encourages guests to open the centre section and that automatically operates the light. The internal unit then swivels 80° left, right and 90° forwards to give a full range of warm directional reading light. Closing the unit then switches it off. The product comes with a LED driver for remote mounting. See page 128 for technical detail.

Materials:
Steel and aluminium.

Finishes:
Brushed Brass (BRB), Brushed Nickel (BN), Matt White (MW), or Satin Black (BL). See page 128 for custom combination finishes available with minimum quantities of 50 pieces.

Registered European Community Design
007575014-0001/0002/0003/0004/0005
US Design Patent Application US29/729,141



Copyright 2020 Chelsom Ltd

LED EYE

Illustrated below are examples of combination finishes available to special order for a minimum quantity of 50 pieces.

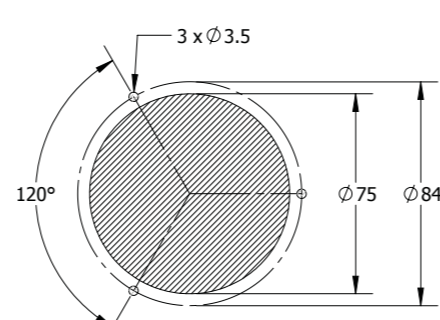
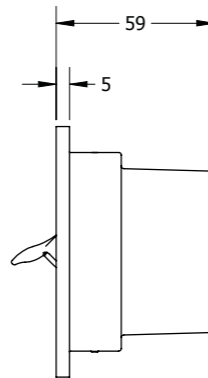
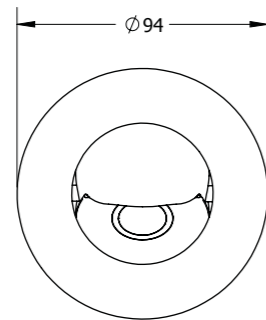
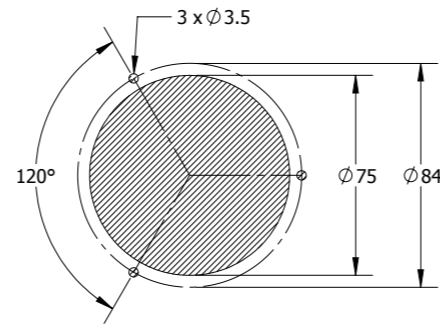
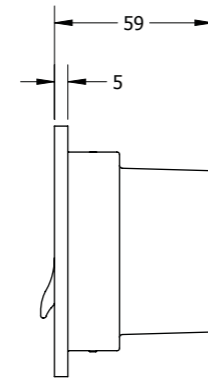
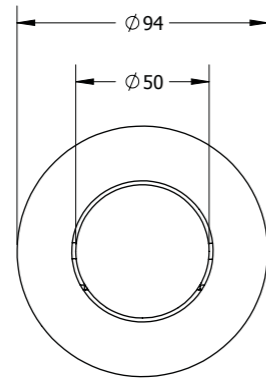

Cutout 75mm Ø

Wiring diagram including remote driver

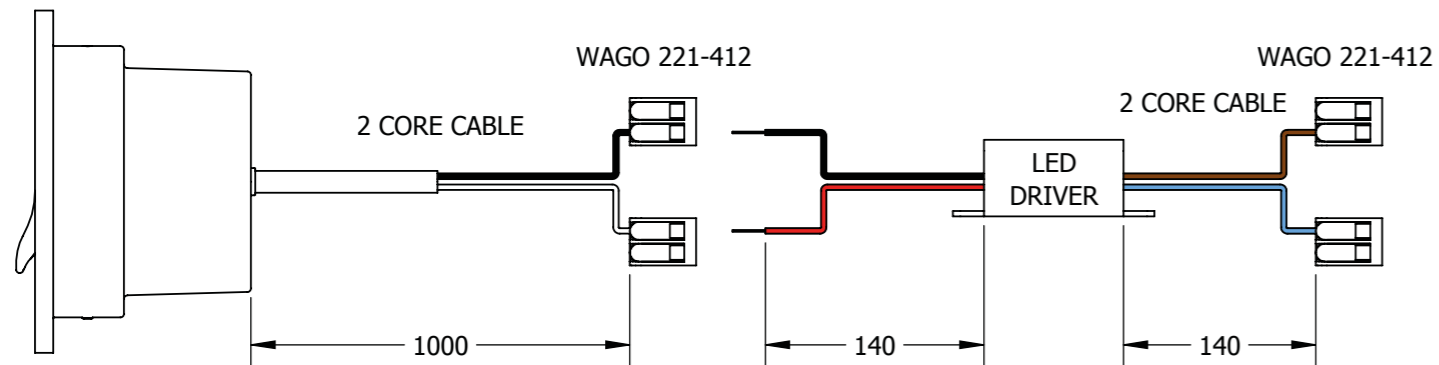

LED DOCK KNURL

Features: A warm white LED reading light is housed within a knurled cylinder head that swivels 90° left, right or forward. A docking switch activates the light source when the head is pulled forward. The product can be vertically or horizontally mounted. For dimensions and technical details, see page 133.

Materials:
Steel and aluminium.

Finishes:
Brushed Brass (BRB),
Brushed Nickel (BN)
or Satin Black (BL).



Copyright 2020 Chelsom Ltd

LED DOCK

Features: A warm white LED reading light is housed within a rectangular or cylindrical head that swivels 90° left, right or forward and 'docks' into a semi recessed backplate, which can be vertically or horizontally mounted. Finishes, docking and push switch options plus installation information, are shown on this and the following pages.

Materials:
Steel and aluminium.

Finishes:
Polished Chrome (C), Black Bronze (BB), Black Bronze with English Brass (BB/EBR), Satin Black with Chrome (BL/C), Brushed Nickel (BN) and English Brass (EBR).

Project: LED DOCK at ABode Glasgow.
Designer: 10 Design.

LED/5/1/BB/EBR
LED 1W 2700K
CE U_L IP20



Copyright 2020 Chelsom Ltd

LED DOCK

Features: See page 130. The Dock range can be offered to special order with an integral USB port fitted for minimum 50 pieces. Note: LED driver is integral but USB transformer is remote – see diagram below. For headboard mounting only.

Materials:
Steel and aluminium.

Finishes:
Polished Chrome (C), Black Bronze (BB), Black Bronze with English Brass (BB/EBR), Satin Black with Chrome (BL/C), Brushed Nickel (BN) and English Brass (EBR).

Switching options:

Available with automatic docking switch in the backplate recess or with shallow push switch in the base of the backplate (except USB version).

Installation:

For simple installation, headboards can be prepared incorporating cutouts and fixing holes as shown in the templates below. Units come complete with switch, LED driver and terminal block fitted to the back for ease of electrical installation. Once connections are made the internal backplate is screwed to the headboard recess and finally the front cover plate is fitted with one discrete locating screw at the bottom.

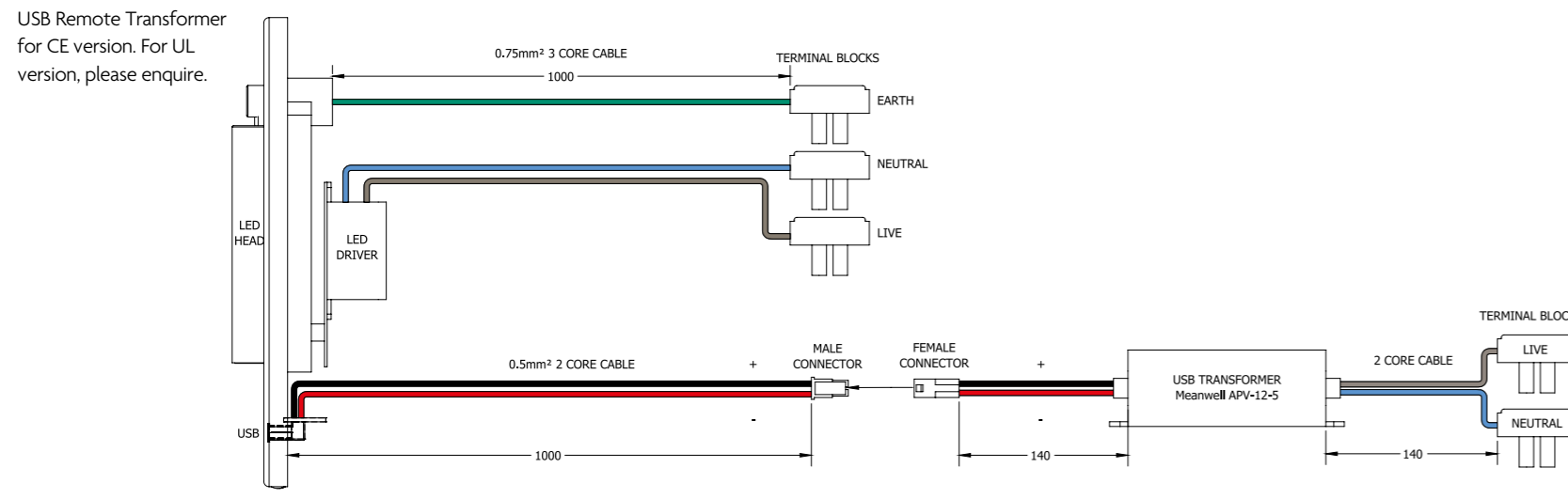
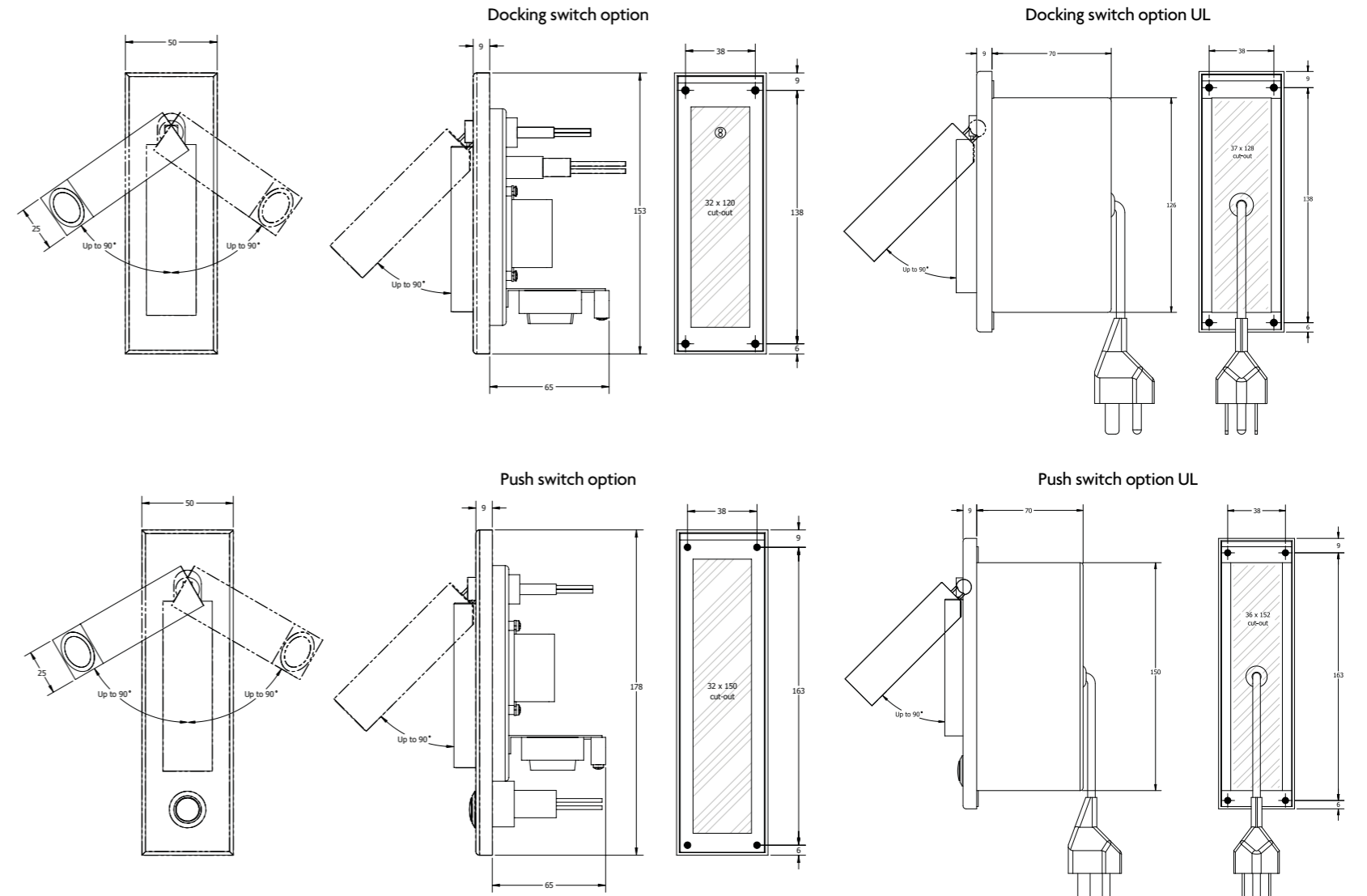
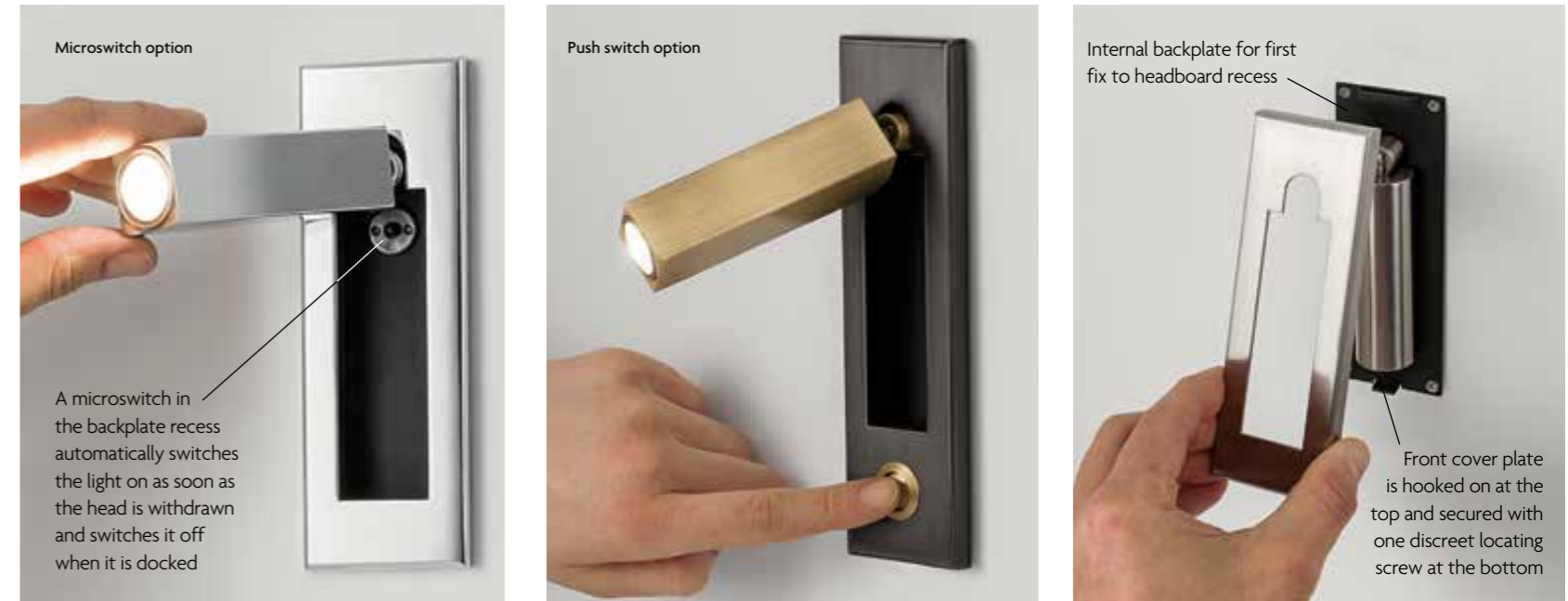

LED DOCK Combi

Features: Combination wall lights with docking switches for the LED heads housed in the backplates. The ambient room light sits within a fabric shade. Products are right and left handed for bedside use.

Materials:
Steel and aluminium.

Finishes:
Black Bronze with English Brass (BB/EBR), Satin Black (BL), or Brushed Nickel (BN).

Shades:
Shades are bespoke for this range. Other fabric options available.



Features: Slender guestroom or cabin bedside wall lights with main room illumination from within the fabric shade, an LED reading light and a USB charging port. The reading light has a docking switch, the main light a push switch. The USB port remains powered even when lights are switched off.

Materials:
Steel and aluminium.

Finishes:
Black Bronze (BB) or Polished Chrome (C).



Copyright 2020 Chelsom Ltd

LED KNURL

Features: The cylindrical heads have detailed knurling and a black on/off push switch. All three finishes are available with rectangular backbox housing an integral driver or with discrete round backplate with concealed fixings for remote driver location. Prices include **integral or remote driver**. An option with integral USB port and **remote transformer** is available for minimum quantity 50 pieces and for headboard mounting only.

Material:
Steel.

Finishes:
Black Bronze (BB),
Brushed Nickel (BN)
and Brushed Brass (BRB).

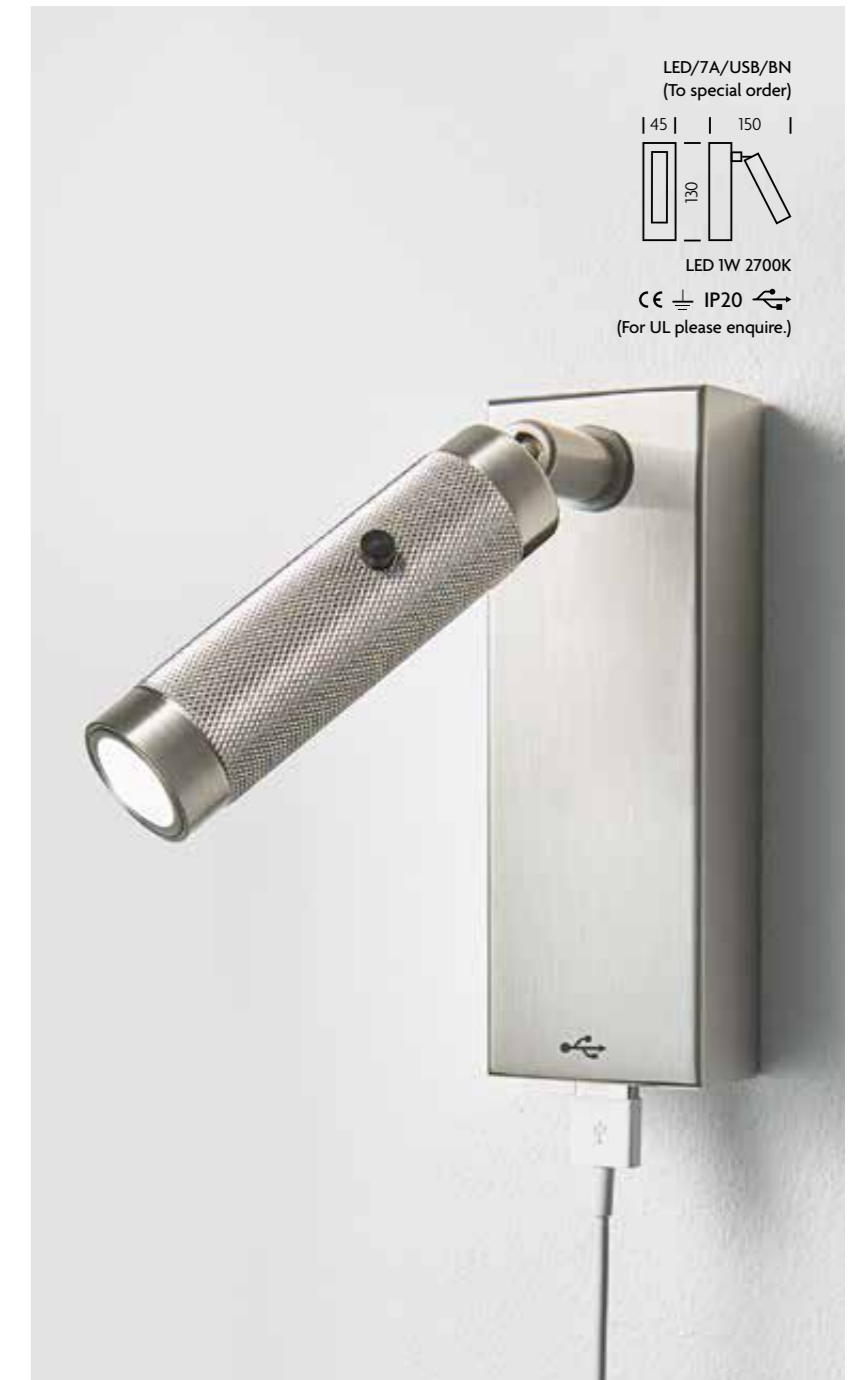

Copyright 2020 Chelsom Ltd

LED FOCUS

Features: The cylindrical heads have a black on/off push switch. Rectangular backbox houses an integral driver or discrete round backplate has concealed fixings for remote driver. **Prices include integral or remote driver.** An option with integral USB port and remote transformer is available for minimum quantity 50 pieces and for headboard mounting only. Combination wall lights are available for double or twin bed configurations with main light switched remotely (integral switching to special order for minimum 50 pieces).

Material:
Steel.

Finishes:
Black Bronze (BB), Brushed Nickel (BN), Brushed Brass (BRB), Satin Black (BL) or Polished Chrome (C).

LED/10/C

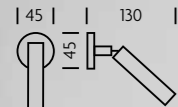

Cutout 25mm Ø

LED 1W 2700K

CE U_L IP20



LED/10A/BB

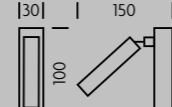

LED 1W 2700K

CE U_L IP20



LED/10/BL



LED/10/BRB



LED/10A/USB/BN
(To special order.)

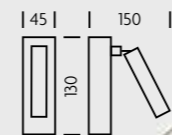

LED 1W 2700K

CE U_L IP20 
(For UL please enquire.)



LED/10/W1/BN with
optional shade QL10/GM

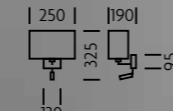

1 x E27 7W LED 2700K
plus 1 x LED 1W 2700K

CE U_L IP20



LED/10/W2/C with
optional shade QL10/OY

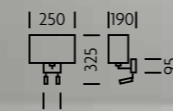

1 x E27 7W LED 2700K
plus 2 x LED 1W 2700K

CE U_L IP20



Copyright 2020 Chelsom Ltd

LED CLASSIC

Features: For the more traditional interior, LED Classic features a detailed backplate with integral toggle switch and a sculptured head secured by knurled rings on a stirrup bracket. **Prices include remote driver.**

Material:
Steel

Finishes:
English Brass (EBR), Black Bronze (BB), Brushed Nickel (BN) or Polished Chrome (C).



LED DOME

Features: A fully adjustable domed head containing a high quality focusing lens allows a perfect spill of directional light. The light is activated by a metal push switch and there is a USB port which is permanently powered. The product has an integral driver located within the backbox. There are four decorative knurled front face screws.

Material:
Steel.

Finishes:
Satin Black with Brushed Brass (BL/BRB) or Satin Black with Brushed Nickel (BL/BN).



LED READING

Features: A collection of reading lights with either grooved cylindrical heads or tapered designs and high quality focussing lenses. Backplates are for integral or remote switching.
Prices include integral or remote driver. Note: Flexi arms are robust 10mm diameter.

Material:
Steel.

Finishes:
Brushed Nickel (BN), Brushed Brass (BRB),
Satin Black (BL), Polished Chrome (C) and
Aluminium (AL). LED/100/300/350/500/800
are only available in BN, BRB and C.

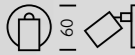

LED/750/BRB
| 60 | | 65 |

Cutout 45mm Ø
LED 1W 2700K
CE U_L IP20



LED/418/SW/AL
| 60 | | 100 |

Cutout 45mm Ø
LED 1W 2700K
CE U_L IP20



LED/100/BN

| 235 |
Cutout 10mm Ø
LED 1W 2700K
CE U_L IP20



LED/350/BN (Also available with toggle switch
as LED/300/* - minimum quantity 50 pieces)

| 235 |
Cutout 45mm Ø
LED 1W 2700K
CE U_L IP20



LED/500/C

| 265 |
LED 1W 2700K
CE U_L IP20



LED/800/C with optional
shade QOB/12/W

1 x E27 7W LED 2700K
plus 1 x LED 1W 2700K
CE U_L IP20



LED/418/BL
| 32 | | 100 |

Cutout 14mm Ø
LED 1W 2700K
CE U_L IP20



Project: LED READING at Sheraton
Grand London Park Lane.
Designer: MKV Design.

LED/418/SW/C

Copyright 2020 Chelsom Ltd

DESK

Project: ROCK at Hilton Diagonal Mar Barcelona.
Designer: The Hickson Design Partnership Ltd.



Rock Desk Lamp 146



Rock Desk Lamp 147



Desk Canopy 148



Desk Hubcap 149



Desk Study 150



Biblio 152



LED Desk Knurl 153



Desk Crane 154



Balance 155

Copyright 2020 Chelsom Ltd

ROCK Desk Lamp

Features: Lamps feature heavy Natural stone bases. For DL/16/BB/EBR, shade swivels and adjusts. SW/40/TL/EBR/STONE has a robust detailed hinge allowing the arm to swivel and the head rotates to give directional reading light. Both models are suitable for bedside or desk use.

Materials: Steel and natural stone.

Finishes: English Brass with Natural stone for SW/40/TL/EBR/STONE and Black Bronze with English Brass and Natural stone for DL/16/BB/EBR.



Desk CANOPY

Features: Adjustable canopy gives good light direction with internal reflector plate. Colour co-ordinated push switch in base.

Material:
Steel.

Finishes:
Black Bronze with English Brass (BB/EBR) or Satin Black with Chrome (BL/C).



Desk HUB CAP

Features: Desk lamp has an integral LED light source and a colour co-ordinated push switch in base. Opal acrylic diffuser gives good diffused light.

Materials:
Steel with acrylic diffuser.

Finishes:
Black Bronze with English Brass (BB/EBR) or Polished Chrome (C).



Desk STUDY

Features: Desk lamps with heavy stepped bases and two toothed locking key swivel joints. Bases include integral toggle switch. Other shade fabric options are available to special order.

Material:
Steel.

Finishes:
Black Bronze with English Brass (BB/EBR), Polished Chrome (C) or English Brass (EBR).

DL/12/BB/EBR with optional shade Q12/OY



1 x E27 7W LED 2700K
CE U_L IP20



DL/12/C with optional shade Q12/BL



DL/12/EBR with optional shade Q12/IVPL



Copyright © 2020 Chelsom Ltd

Project: STUDY at Mandarin Oriental Hyde Park, London.
Designer: Joyce Wang Studio.

BIBLIO

Features: A stepped base, deeply grooved directional handle and decorative key toothed locking joints are key features of this desk lamp. The arm rotates at the column step and the canopy head swivels left/right. Shade interior is White painted for extra illumination.

Material:
Steel.

Finishes:
Black Bronze with English Brass (BB/EBR) or Polished Nickel (PN).



LED Desk KNUURL

Features: A compact desk lamp with a knurled cylindrical head which incorporates an on/off switch. The head swivels left, right and forward.

Material:
Steel.

Finishes:
Brushed Brass (BRB),
Brushed Nickel (BN)
or Satin Black (BL).



Copyright 2020 Chelsom Ltd

Desk CRANE

Features: Warm white LED light source allows diffused light from slim arm. Desk lamp arm swivels 90° left and right – floor lamp arm is fixed. Desk lamp has colour co-ordinated push switch in the base.

Materials:
Steel with acrylic diffuser.

Finishes:
Satin Black with Chrome (BL/C). Polished Chrome and other finishes available to special order for minimum quantities.

CR/7/DL/BL/C

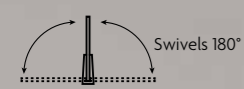

LED 7W 2700K
CE U_L IP20

CR/7/FS/BL/C

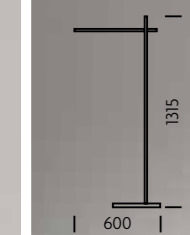

LED 8.5W 2700K
CE U_L IP20



BALANCE

Features: A multi-directional bedside or reading light. Arm positions adjust at two separate points secured by locking keys. Heads are held in a stirrup mechanism for adjustment. Metal shades are White inside.

Materials:
Steel and aluminium.

Finish:
Satin Black with Aluminium accents.

BC/10/TL

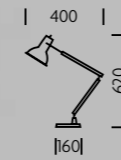

1 x E27 7W LED 2700K
CE U_L IP20

Copyright 2020 Chelsom Ltd



DESK

The Desk Lamps here are from Collections illustrated elsewhere in the catalogue and page cross references are shown.



The Chelsom Value Award is given to ranges which represent exceptional value alongside high design and quality standards.



AS/36/TL/BL/BRB. See page 36 for full range and details



HY/77/TL/BN. See page 41 for full range and details



LX/6/TL. See page 45 for full range and details



RM/9/TL. See page 67 for full range and details



RA/4/L. See page 68 for full range and details



SW/40/TL/C. See page 89 for full range and details



PP/12/TL. See page 53 for full range and details



HQ/15/TL. See page 47 for full range and details



SY/45/TL/BL/GB. See page 50 for full range and details



TO/10/TL/EBR. See page 99 for full range and details



PT/4/TL/BL. See page 105 for full range and details



CK/6/TL. See page 57 for full range and details



SE/14/DL/BL/BRB. See page 62 for full range and details



AL/52/DL/C. See page 108 for full range and details



PJ/9/DL/C. See page 117 for full range and details



IN/12/DL/BNC. See page 119 for full range and details

Copyright 2020 Chelsom Ltd

BATHROOM



The Chelsom Value Award is given to ranges which represent exceptional value alongside high design and quality standards.



Project: BATHROOM LIGHTING at Kimpton Fitzroy, London.
Designer: Tara Bernard & Partners.



Custom Mirrors 160



Bathroom Mirrors 162



Bathroom Mirrors 162



Bathroom Mirrors VA 162



Bathroom Mirrors 162



Bathroom Deluxe 163



Bathroom Deluxe 163



Bathroom Deluxe 163



Bathroom Deluxe 163



Bathroom 164



Bathroom 164



Bathroom 164



Bathroom 165



Bathroom 165



Bathroom 166



Bathroom 166



Bathroom 167



Bathroom 167



Bathroom 167



Bathroom VA 167

Copyright 2020 Chelsom Ltd

Bathroom CUSTOM MIRRORS

Chelsom are specialists in the design and manufacture of custom mirrors for the global hospitality market. All sizes and shapes can be considered together with different light sources and different metal finishes. There may be minimum quantity requirements. Please contact Chelsom with any enquiry.



Project: CUSTOM MIRRORS at DoubleTree by Hilton Hull.
Client: Hilton Hotels and Resorts.
Designer: Hampton Design.

Project: CUSTOM MIRRORS at Lincoln Plaza London, Curio Collection by Hilton.
Client: Hilton Hotels and Resorts.
Designer: RPW Design.



Project: CUSTOM MIRRORS at One Aldwych.
Designer: Robert Angell Design International.

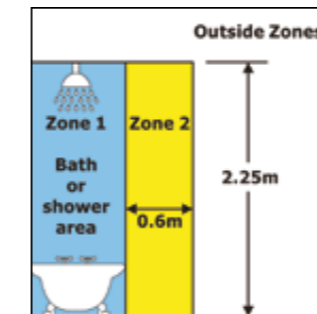

REQUIREMENTS BASED ON REGULATIONS FOR LUMINAIRES IN AREAS CONTAINING A BATH OR SHOWER

For the purpose of defining the regulations, the bathroom is divided into two zones as shown above. In any room containing a bath or shower, protection by a RCD (Residual Current Device) of 30 mA with a response time of 0.4 seconds is required for each circuit.

Zone 1

The area above that defined by the perimeter of the bath or shower tray. Only fittings supplied from a remote 12V transformer and having a minimum rating of IPx5 are recommended.

Zone 2

Area adjoining bath or shower tray. Outside the perimeter of the bath or shower up to a distance of 600mm, fittings with a minimum IPx4 rating are required, either mains or low voltage.

Outside of Zones

The remaining area of the bathroom beyond Zone 2.

In this area any mains or low voltage luminaire can be used if protected by an RCD.

Only bath or shower areas are relevant in these regulations – washbasins are not. If water jets are used (this does not include shower heads), then IP55 is required.



Project: CUSTOM MIRRORS at Movenpick Hotel Paris Neuilly.
Client: Movenpick Hotels and Resorts.
Designer: ARA Design.

Bathroom MIRRORS

Features: Shaving mirror, BW/110/LED, is fully adjustable with an integral LED light source. BW/116/LED has an integral shaver socket and demister pad as standard (other mirrors can have the demister pad option). IP ratings and zone positions are shown. Please refer to the diagram on page 161.

Materials: Steel or aluminium with glass.

Finishes: Polished Chrome for BW/110/LED. White painted backbox for BW/116/LED and Brushed Gold (BRG) or Satin Black (BL) for BW/220 and BW/230. Special finishes available for minimum order quantities of 50 pieces.



Bathroom DELUXE

Features: For all models except LN/34/WW/C, the G9 LED light source is housed within a waterproof frosted glass diffusing capsule. Where wipeable fabric shades are shown, prices and dimensions include those shades. LN/34/WW/C has a faux stone backplate detail. IP ratings and zone positions are shown. Please refer to the diagram on page 161.

Materials: Steel or brass with glass diffusers or fabric shades.

Finishes: Polished Nickel except LN/34/WW/C which is Polished Chrome.



Copyright 2020 Chelsom Ltd

BATHROOM

Features: Elegant bathroom lighting for contemporary interiors. For BW/21/*, the LED light spreads evenly throughout the Opal diffuser and reflects off the curved backplate. For BW/82/*, LED light evenly fills the full lengths of the frosted solid acrylic rods. IP ratings and zone positions are shown. Please refer to the diagram on page 161.

Materials: Steel with acrylic diffusers.

Finishes: Polished Chrome (C) or Brushed Brass (BRB). Also Black Bronze (BB) for BW/21/* or Satin Black (BL) for BW/82/*. Diffuser for BW/21/* is Opal and for BW/82/* is Clear frosted.



Features: GM/66/W1/* features domed end caps with detailed knurling around the light source. BW/73/* features hexagonal shaped columns with faux alabaster acrylic panels. Both designs are also suitable for bedside, corridors and public spaces. IP ratings and zone positions are shown. Please refer to the diagram on page 161.

Materials: Steel with glass for GM/66/* and steel with acrylic for BW/73/*.

Finishes: Polished Chrome (C), Brushed Brass (BRB) or Satin Black (BL) with matt Opal glass diffuser for GM/66/* and faux alabaster acrylic diffuser for BW/73/*.



Copyright 2020 Chelsom Ltd

BATHROOM

Features: Nimbus models, NM/6/*, feature shallow framed backboxes and light emitted through faux alabaster acrylic diffusers. DT/14/W2/C, features two matt Opal globes within a Clear glass cylinder. DU/6/W2/C, features matt Opal globes with a central joining Chrome detail. For PJ/9/W1/IP44, price and dimensions include wipeable fabric shade.

Materials:

Steel or aluminium with glass or acrylic.

Finishes:

Polished Chrome (C) with faux alabaster acrylic for NM/6/* models and Clear and matt Opal glass for DT/14/W2/C and DU/6/W2/C. BW/112/LED is Chrome with Opal diffuser.



Copyright 2020 Chelsom Ltd

TABLE & FLOOR



Poise 170



Shadow 171



Oslo 172



Cradle 173



Glass Art Milk 182



Glass Art Bronze 183



Provence 184



Thames 185



Laguna 174



Laguna 175



Laguna 176



Laguna 177



Thames 185



Console 186



Vogue 187



Seed Glass 188



Glass Sculpture 178



Glass Art Smoke 179



Stockholm 180



Stockholm 181

Copyright 2020 Chelsom Ltd



Check In 189



Silver Sculpture 190



Floor 191



Table Lamps 192

POISE

Features: Shallow top canopies with detailed top washers conceal warm white LED light shining down through an Opal acrylic diffuser.

Materials:
Steel and acrylic diffuser.

Finishes:
Golden Bronze (GB) or
Satin Black with Golden
Bronze (BL/GB).

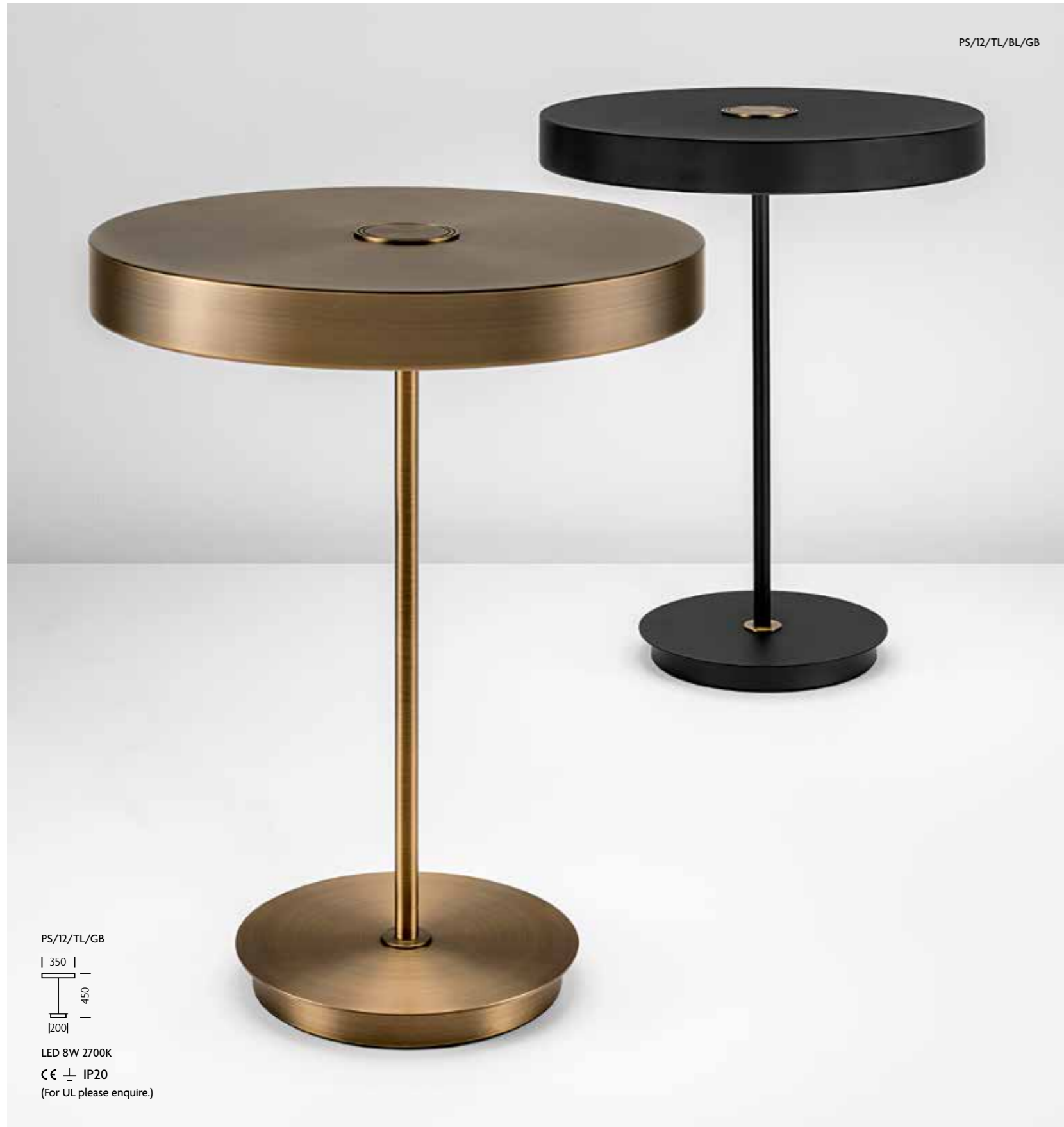

SHADOW

Features: A Brushed Brass outer frame holds faux alabaster panels on both sides emitting a warm ambient light forwards and backwards. The frame slots within a heavy Brushed Brass cylindrical section and the table lamp stands on three clear rubber feet. Table lamp has an inline dimmer switch and the wall light can be mounted with different orientations.

Materials:
Steel and acrylic.

Finish:
Brushed Brass
with faux
alabaster.



OSLO

Features: Mouthblown glass is matched with English Brass caps and bases. Tapered perforated brass columns feature inside the glass.

Materials:
Glass and steel.

Finish:
Clear glass with English Brass.



CRADLE

Features: Fine tubular metal frames create a 'cradle' to hold mouthblown matt Opal glasses which give a soft glow of light. Legs have black rubber feet. **DIMENSIONS AND PRICES INCLUDE GLASS.**

Materials:
Steel and glass.

Finishes:
Satin Black (BL) or Golden Bronze (GB) with matt Opal glass.



LAGUNA

Features: Rediscovered artisan glass moulds which had lain unused since the 1960s create stunning geometric patterned mouthblown glass table lamps.

Materials:
Glass with steel.

Finishes:
Olive glass with Black Bronze metalwork and Gold silk-covered cable,
Mocca glass with Golden Bronze metalwork and Gold silk-covered cable
or Aqua glass with Brushed Nickel metalwork and Silver silk-covered cable.



Copyright 2020 Chelsom Ltd

LAGUNA

Features: Rediscovered artisan glass moulds which had lain unused since the 1960s create stunning geometric patterned mouthblown glass table lamps.

Materials:
Glass with steel.

Finishes:
Olive glass with Black Bronze metalwork and Gold silk-covered cable,
Mocca glass with Golden Bronze metalwork and Gold silk-covered cable
or Aqua glass with Brushed Nickel metalwork and Silver silk-covered cable.



Copyright 2020 Chelsom Ltd

GLASS SCULPTURE

Features: Heavy, solid Smoke glass centre with Clear glass outer is hand sculpted, making every piece unique with slight variations in shape and blend of colours. Silver silk covered cable runs externally.

Materials: Hand formed Veneto solid glass with dual colours and steel metalwork.

Finishes: Smoke with Clear glass and Black Bronze metalwork. Also available with Chrome metalwork.

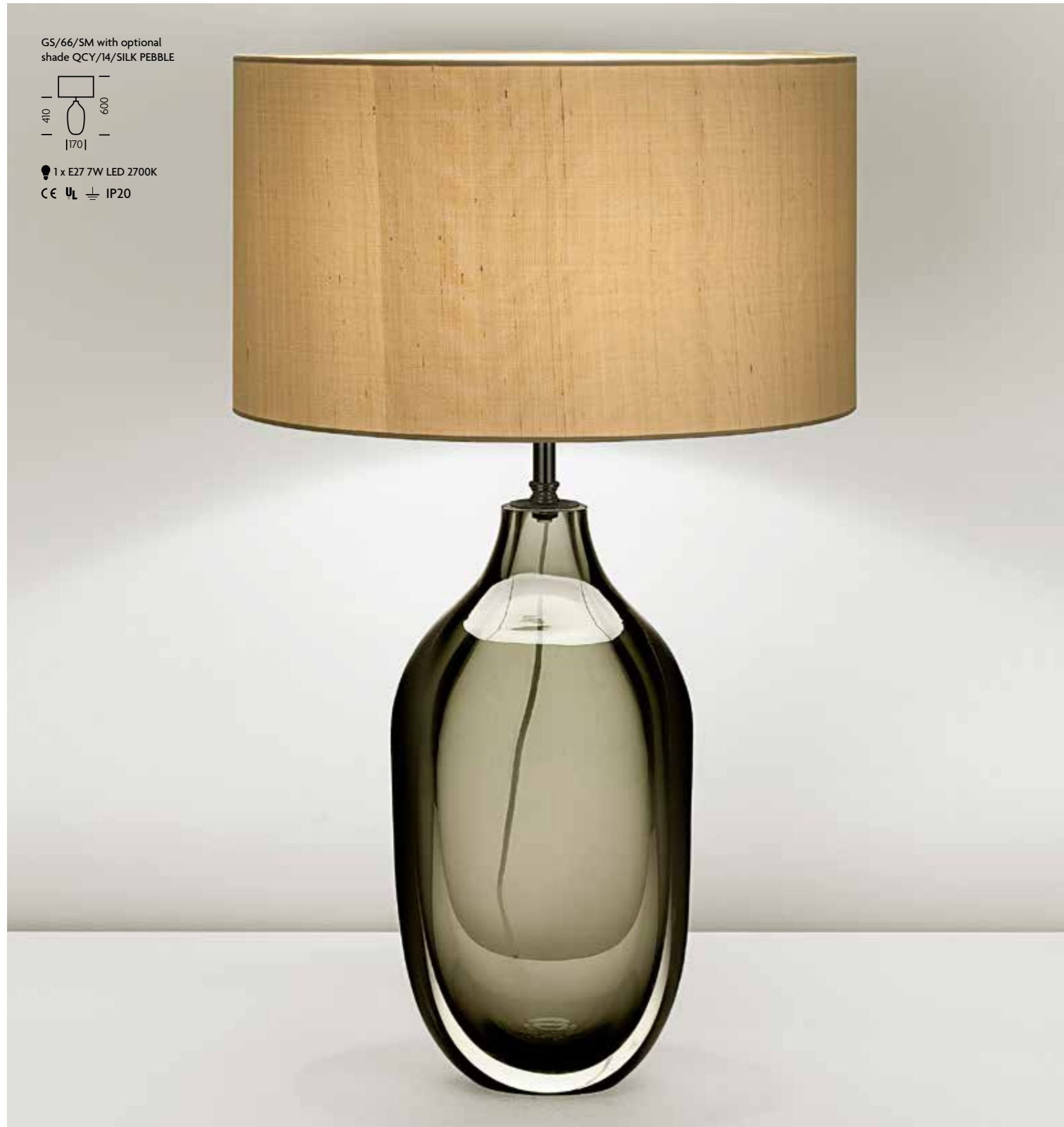

GLASS ART Smoke

Features: Mouth blown heavy glasses have a random horizontal ribbing. Silk covered cable runs internally.

Materials: Mouth blown Veneto glass with steel metalwork.

Finish: Smoke glass with Black Bronze metalwork.



STOCKHOLM

Features: Clean lines and seamless joints between glass and metalwork with internal silk-covered colour matched cables.
SK/28/BN has heavy, horizontal ribbing in the metalwork.

Materials:
Steel and glass.

Finishes:
English Brass (EBR) with Clear glass or Brushed Nickel (BN) with iridescent Smoke glass.

Shades:
See back of catalogue for optional shades.



SK/28/BN with optional shade QCY/16/GM

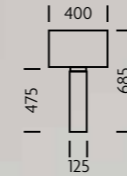

1 x E27 7W LED 2700K
CE U_L IP20



SK/26/BN with optional shade QST/18/GM

1 x E27 7W LED 2700K
CE U_L IP20

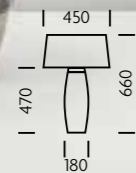

SK/24/BN with optional shade QST/18/GM

1 x E27 7W LED 2700K
CE U_L IP20

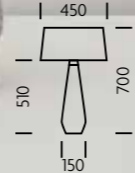

SK/24/EBR with optional shade QST/18/WGO

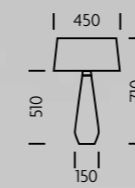

1 x E27 7W LED 2700K
CE U_L IP20



SK/27/EBR with optional shade QCY/16/WGO

1 x E27 7W LED 2700K
CE U_L IP20

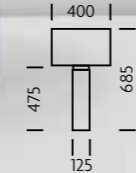

SK/26/EBR with optional shade QST/18/WGO

1 x E27 7W LED 2700K
CE U_L IP20

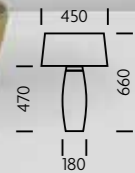

Copyright 2020 Chelsom Ltd

GLASS ART Milk

Features: Mouthblown sculptured glass is matched with Brushed Brass caps and bases. Special glass colours for minimum 200 pieces.

Materials:
Glass and steel.

Finish:
Milk Opal glass with
Brushed Brass.



GA/59 with optional shade QST/18/NAT

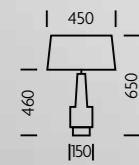

1 x E27 7W LED 2700K
CE U L IP20

GLASS ART Bronze

Features: Mouthblown geometric Bronze glass is matched with subtle Brushed Brass metalwork. Gold silk-covered cable runs internally.

Materials:
Steel and glass.

Finish:
Bronze glass with Brushed
Brass metalwork.



GA/29 with optional shade QST/20/NAT

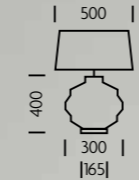

1 x E27 7W LED 2700K
CE U L IP20

GA/28 with optional shade QST/16/NAT



1 x E27 7W LED 2700K
CE U L IP20

Copyright 2020 Chelsom Ltd

PROVENCE

Features: Rectangular section tubes are formed into geometric patterns and are set onto heavy natural stone bases.

Materials:
Steel and stone.

Finish:
Brushed Brass metalwork
with natural stone base.



THAMES

Features: Solid blocks of polished natural stone are framed with Brushed Brass metalwork standing on heavy plinth bases.

Materials:
Steel and natural stone.

Finish:
Brushed Brass with
polished Natural stone.



CONSOLE

Features: A tall slender lamp for use on narrow consoles, side tables or nightstands.

Materials:
Steel and brass.

Finish:
Black Bronze with
English Brass (BB/EBR).

Shades:
See back of catalogue
for optional shades.



VOGUE

Features: Well proportioned conical table lamps using contrasting finish materials.

Materials:
Steel with faux
leather option.

Finishes:
Antique Brass with Black Bronze
(AB/BB) or Antique Brass with
faux leather (AB/LEATHER).



SEED GLASS

Features: Thick, Clear seed glass column is firmly held between silicone gaskets and metal turnings. This robust lamp features random bubbles in Clear glass which pick up the fall of light from the shade.

Materials:
Steel and glass.

Finish:
Brushed Brass (BRB) with Clear seed glass.



SG/24/TL/BRB with optional shade QST/18/NAT

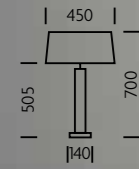

1 x E27 7W LED 2700K

CE U L IP20

CHECK IN

Features: A slim rounded corner rectangular shade is held within the rectangular metal framework of the double columns. See pages 84-86 for the full range.

Material:
Steel.

Finishes:
Brushed Brass (BRB) with black underbase.

Shades:
Shades are bespoke for the Check In range. Fabric shown is Black with Gold lining (BG) with other fabrics available. Shades have integral top diffusers.

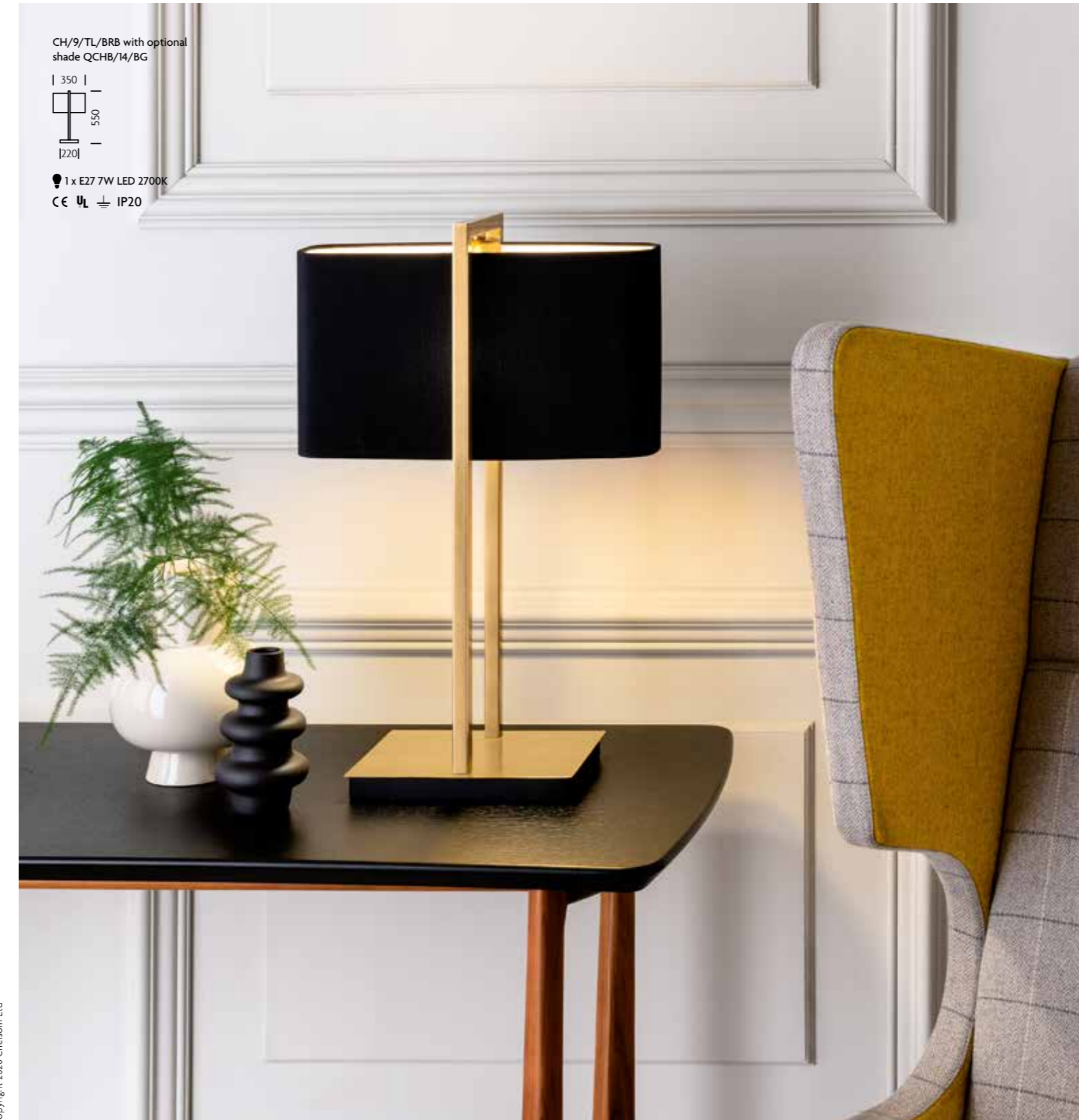

CH/9/TL/BRB with optional shade QCHB/14/BG

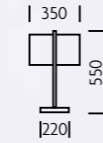

1 x E27 7W LED 2700K

CE U L IP20

Copyright 2020 Chelsom Ltd

SILVER SCULPTURE

Features: Hand forged iron bars with a distressed organic feel are enhanced with hand applied Antique Silver Leaf. See pages 302-303 for matching chandeliers and wall lights.

Material:
Hand forged iron.

Finish:
Florentine Antique Silver Leaf.

Shades:
See back of catalogue for optional shades.



SS/90/FS with optional shade QCY/20/SILK PEBBLE

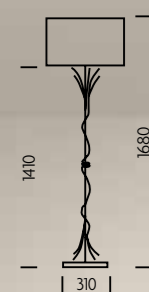

1 x E27 8W LED 2700K
CE U_L IP20

SS/90/TL with optional shade QCY/16/SILK PEBBLE

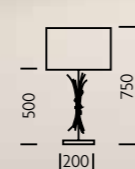

1 x E27 7W LED 2700K
CE U_L IP20

FLOOR

Features: FA/30 has cable running internally down one leg. FA/80 has a curved tripod base section supporting Polished Chrome decorative capping. Top of lamp also has decorative Chrome accents.

Materials:
Wood and steel.

Finishes:
Polished Chrome with Wenge wood on FA/30 and Walnut wood on FA/80.



FA/30 with optional shade QCY/20/NAT

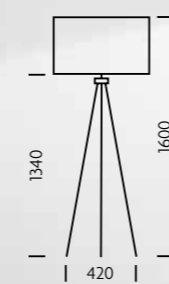

1 x E27 8W LED 2700K
CE U_L IP20



FA/80 with optional shade QST/24/OY

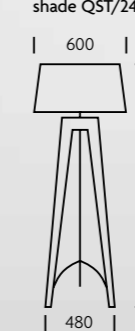

1 x E27 8W LED 2700K
CE U_L IP20

TABLE

The table lamps here are from collections illustrated elsewhere in the catalogue and page cross references are shown.



AS/36/TL/BL/BRB. See page 36 for full range and details



LX/6/TL. See page 45 for full range and details



SX/48/TL. See page 55 for full range and details



CK/6/TL. See page 57 for full range and details



CZ/30/TL. See page 49 for full range and details



BT/8/TL. See page 52 for full range and details



TQ/100/TL. See page 75 for full range and details

Copyright 2020 Chelsom Ltd



SH/60/TL2/BB/EBR. See page 76 for full range and details

WALL

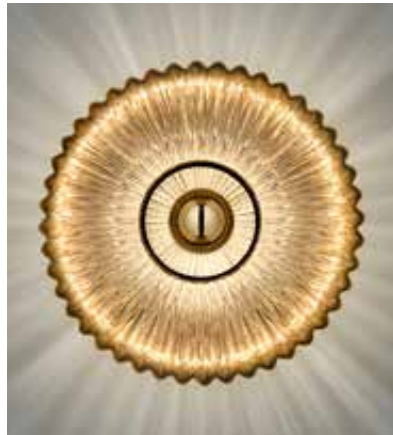

Glass Effect 196



Glass Effect 200



Nimbus 202



Gaumont 206

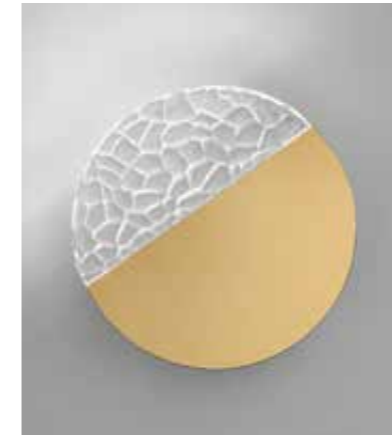

Vetro 219



Feature Wall Lights 220



Cube 221



Solar 222



Motif 207



Octo 208



Shadow 209



Duo 210



Reflector 224



Sconce 226



Room Numbering 227



Broadway 228



Duet 211



Marlow 212



Odeon 213



Boom 214



Direct 229



Prestige Wall Lights 230



Twist 231



Kite 232



Shield 215



Apollo 216



Brunch 217



Lookout 218



Gold Sculpture 233



Pear 234



Classic Exterior 235



Classic Picture Lights 236



Picture Lights 237

GLASS EFFECT

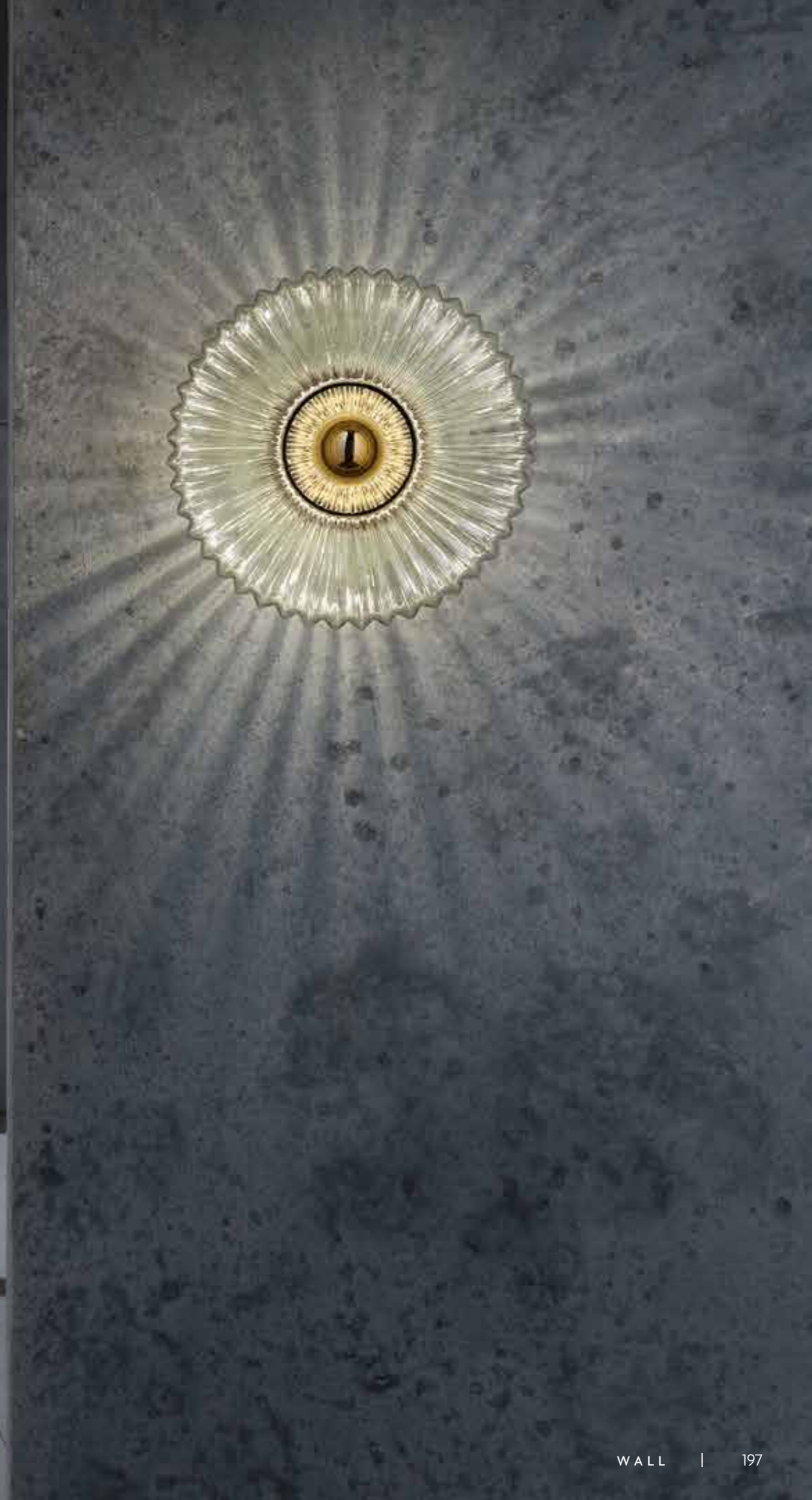

GLASS EFFECT

Features: Deeply ribbed elliptical shaped mouthblown Veneto glass gives a dramatic light effect. The gold topped reflector lamps avoid glare and produce striking patterns of light onto walls. **THE RANGE IS PRICED WITH AND COMES COMPLETE WITH LAMPS AS SHOWN.**

Materials:
Steel and glass.

Finishes:
Brushed Brass metalwork with Mirrored Gold, Smoke or matt Opal glass.

GE/742/SMOKE
| 300 | |160|
○ ○ =100
1 x E27 6W LED 2700K
CE U_L IP20

GE/742/MIRRORED GOLD
| 300 | |160|
○ ○ =100
1 x E27 6W LED 2700K
CE U_L IP20



GE/742/OPAL
| 300 | |160|
○ ○ =100
1 x E27 6W LED 2700K
CE U_L IP20

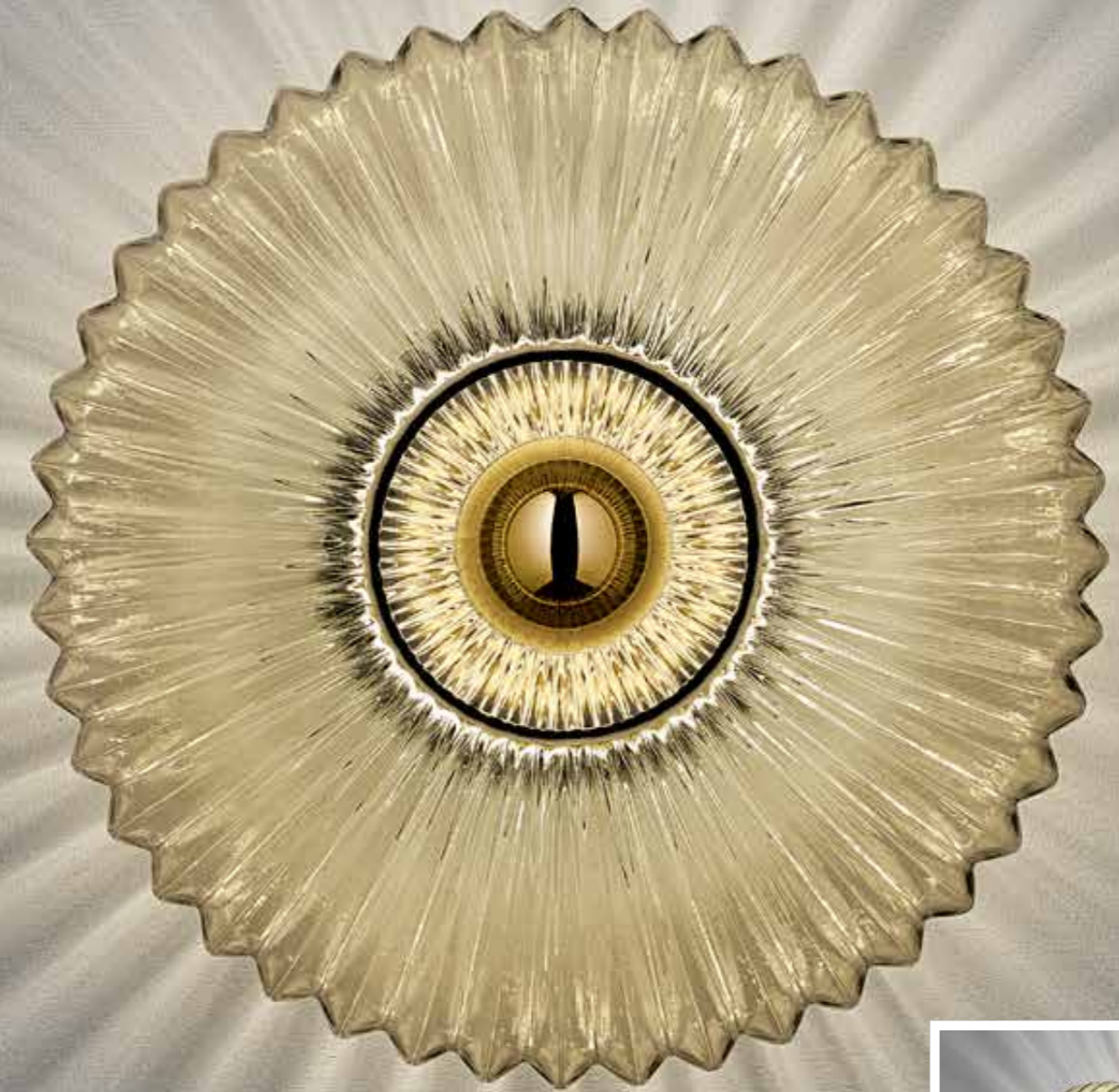
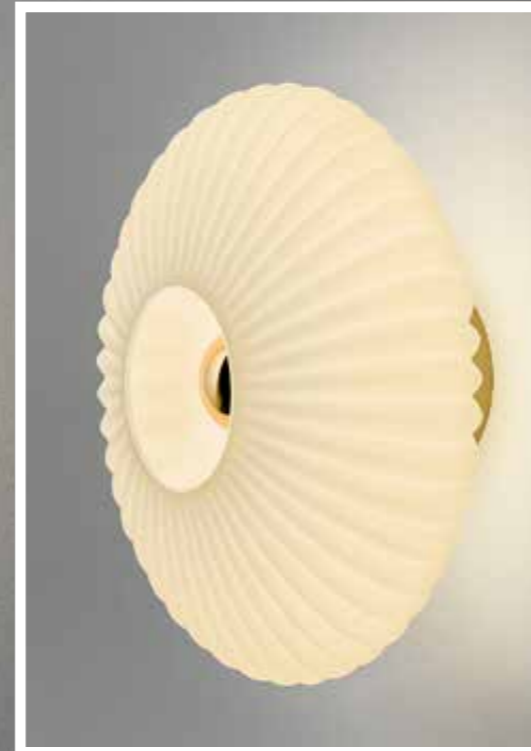

Copyright 2020 Chelsom Ltd

GLASS EFFECT

Features: GS/0470/CL has deep cross-hatched detailing which breaks up the light source to give an ambient glow. GS/1280/GL and GS/20203/GL have Veneto Gold Leaf hand-applied to the back of the glass. This gives a striking golden glow to the front and a crackle pattern at the back where light seeps between individual gold leaf sheets. GS/20203/GL has deep steps in the design creating a concentric ring pattern onto the gold-topped reflector lamp. **THE RANGE IS PRICED WITH AND COMES COMPLETE WITH LAMPS AS SHOWN.**

Materials: Steel and glass.
Finishes: Brushed Brass metalwork with Clear (CL) or Gold Leaf (GL) glass.

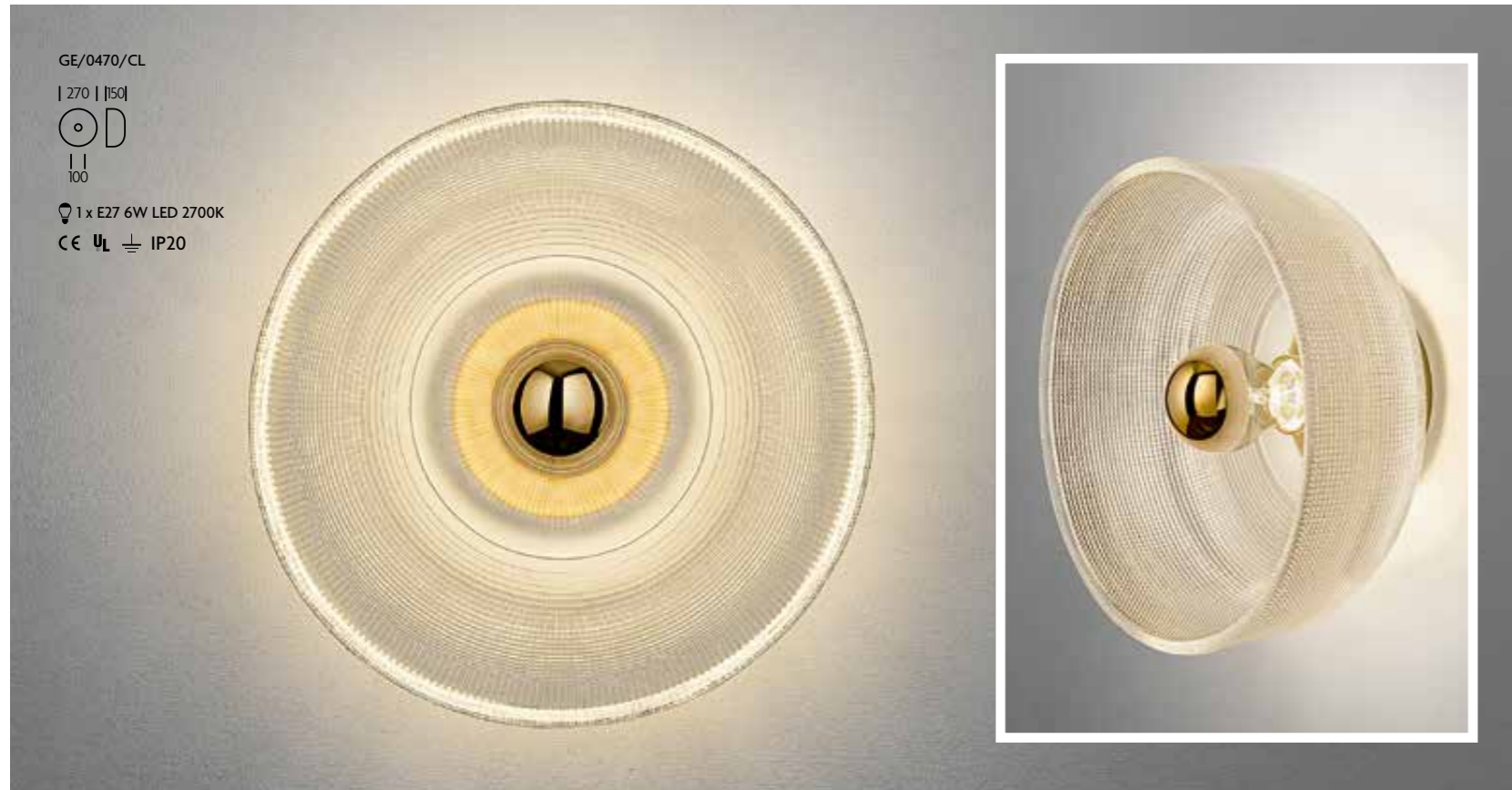

Copyright 2020 Chelsom Ltd

NIMBUS



NIMBUS

Features: Shallow backplates and slender light boxes give a perfectly even spread of warm diffused dimmable LED light through faux alabaster acrylic panels. Different shapes and sizes give great versatility and the square and round options are also ideal for ceiling mounting. NM/6/300x100/LED/BRG has an additional LED reading light for bedside use.

Materials: Steel, aluminium and acrylic.

Finish: Brushed Gold (BRG) metalwork with faux alabaster acrylic.



Copyright 2020 Chelsom Ltd

GAUMONT

Features: A compact bedside wall light featuring domed end caps with knurled detailing and a matt Opal glass diffuser giving a soft ambient light. The model is also suitable for corridors and bathrooms.

Materials:
Steel and glass.

Finishes:
Brushed Brass (BRB),
Satin Black (BL) or
Polished Chrome (C).

GM/66/W1/BL

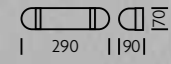

1 x E14 4W LED 2700K

CE U L IP44



GM/66/W1/BRB

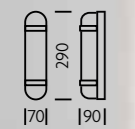

1 x E14 4W LED 2700K

CE U L IP44



GM/66/W1/C



MOTIF

Features: Classic Art Deco styling is featured in frosted acrylic geometric side panelling emitting light forwards and back onto the wall.

Materials:
Steel and acrylic.

Finishes:
Polished Chrome
(C) or Brushed
Brass (BRB).

MF/22/W2/BRB

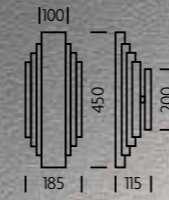

2 x E14 4W LED 2700K

CE U L IP20



MF/22/W2/C



Copyright 2020 Chelsom Ltd

OCTO

Features: A classic octagonal shaped frame encloses a faux alabaster acrylic light panel and octagonal central washer. The octagon sits on a robust square arm.

Materials:
Steel and acrylic.

Finish:
Brushed Brass with
faux alabaster acrylic.



SHADOW

Features: A Brushed Brass outer frame holds faux alabaster panels on both sides emitting a warm dimmable ambient light forwards and backwards. The frame slots within a heavy Brushed Brass cylindrical section. The wall light can be mounted vertically or at an angle and the table lamp has an inline dimmer switch.

Materials:
Steel and acrylic.

Finish:
Brushed Brass with
faux alabaster acrylic.



DUO

Features: A neat two light wall light featuring matt Opal globes mounted onto a rounded rectangular backplate. The globes have a decorative joining collar. The design is for bedroom or corridor and being IP44 rated is also ideal for bathrooms.

Materials:
Steel and glass.

Finishes:
Brushed Brass (BRB) or
Polished Chrome (C)
with matt Opal glasses.



DUET

Features: Matt Opal globes emit soft diffused light inside sparkling Clear glass cylinders. Wall lights are ideal for guestroom or public areas and the globes are threaded for a durable fixing. The glass cylinders sit in concave-shaped backboxes.

Materials:
Steel and glass.

Finish:
Brushed Brass (BRB)
with matt Opal
and Clear glass.



MARLOW

Features: A heavy and deeply ribbed matt Opal cylinder shade sits within a contrasting Golden Bronze frame mounted onto a stepped rectangular backplate. Dimensions and prices include glass shade.

Materials:
Steel and glass.

Finish:
Golden Bronze with
matt Opal glass.



ODEON

Features: Art Deco style mouthblown glass sits in ribbed Brushed Brass detailing. Dimensions and price include glass shade.

Materials:
Steel and glass.

Finish:
Brushed Brass (BRB)
metalwork with
matt Opal glass.



Copyright 2020 Chelsom Ltd

BOOM

Features: Two gently curving triangular Satin Black panels enclose the light source which gives a warm ambient glow from the Brushed Brass interior.

THE RANGE IS PRICED WITH AND COMES COMPLETE WITH LAMPS AS SHOWN.

Material:
Steel.

Finish:
Satin Black with
Brushed Brass.

BM/56/W2

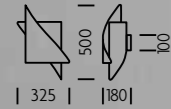

2 x E14 3.5W LED 2100K

CE U_L IP20



BM/56/P (also see page 293)

SHIELD

Features: The perforated metal tapered half shade on the wall light emits a warm glow and throws light onto the oval backplate creating a halo effect around its concave curved perimeter. The chandelier has full conical shades giving the same glow. All shades have Opal acrylic liners to diffuse the light softly. 2500K filament lamp recommended.

Material:
Steel.

Finish:
Golden Bronze
with Satin Black.

SF/29/W1



1 x E27 6W LED 2500K

CE U_L IP20



SF/29/8 (also see page 265)



Copyright 2020 Chelsom Ltd

APOLLO

Features: Matt Opal glass globes are centred within shallow cones which reflect the warm glow of light. Pendant is suspended with black silk covered cable.

Materials:
Steel and glass.

Finish:
Brushed Brass with
matt Opal glass.

AO/007/W1



| 350 | |145|

● 1 x E14 3W LED 2700K

CE U_L IP20

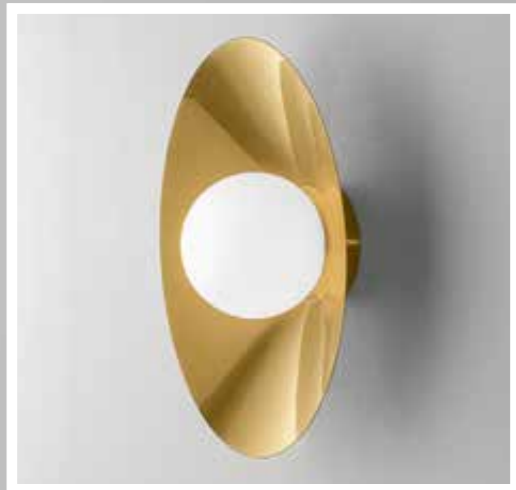
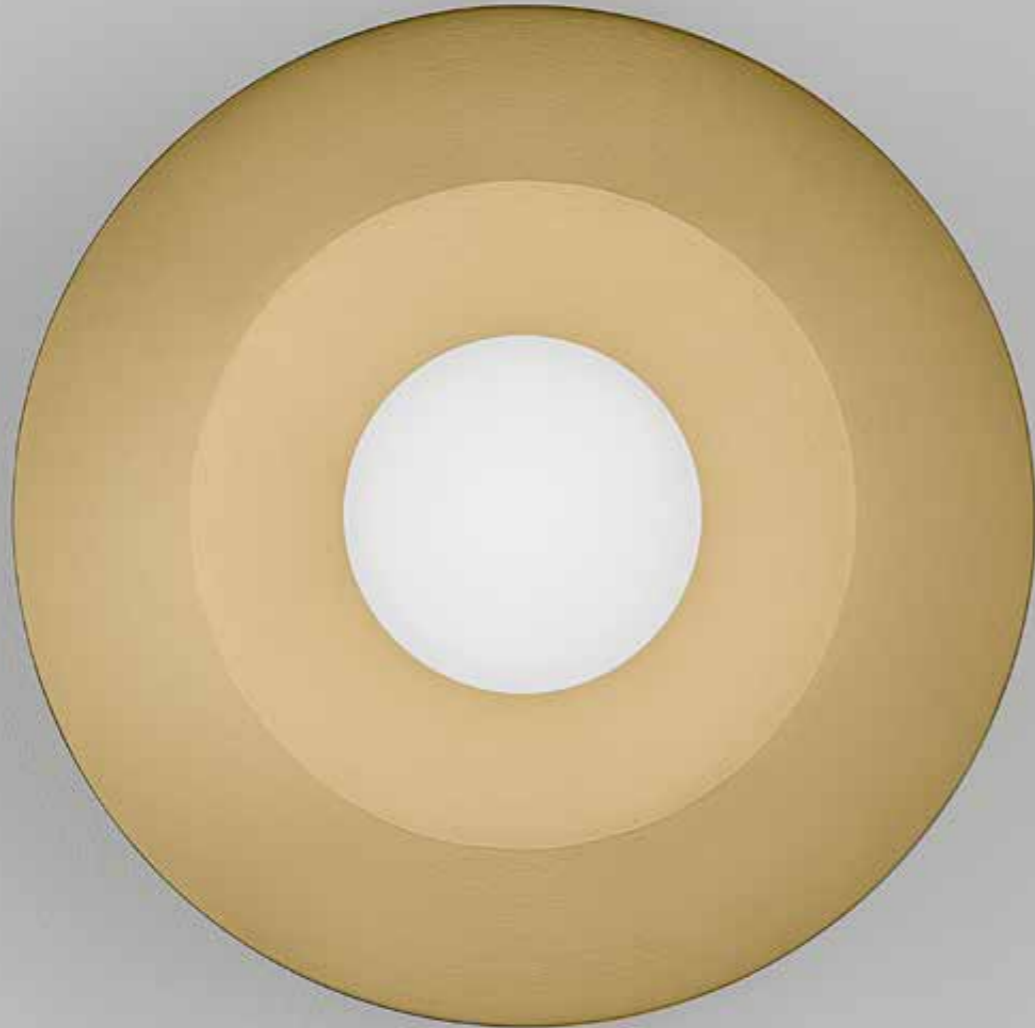

AO/007/P (also see page 295)

BRUNCH

Features: Hand spun metal shades have detailed rolled edges and good light output from White interiors. Pendants are suspended with black silk-covered cable.

Material:
Steel.

Finishes:
Brushed Brass with
Satin Black accents
(BRB) or Satin Black (BL).

BH/40/W1/BRB



● 1 x E27 7W LED 2700K

CE U_L IP20



BH/40/W1/BL



BH/40/P/BRB (also see page 294)

LOOKOUT

Features: Highly decorative wall light whose curved metal arm holds a domed Clear Crackle glass producing a patterned light spill onto the wall.

THE PRODUCT IS PRICED WITH AND COMES COMPLETE WITH LAMP AS SHOWN.

Materials:
Steel and glass.

Finish:
Brushed Brass with
Clear Crackle glass.



LK/10/W1
| 230 |
E14 190 | 180 |
50 | 190 |
1 x E14 3W LED 2200K
CE U L IP20

LK/10/W1

VETRO

Features: Slim Brushed Brass discs conceal dimmable warm LED light which projects into the thick sculptured glass dramatically illuminating the moulded pattern and the outer perimeter. VE/2/3P is supplied with fixed suspension rods and VE/2/P hangs on a clear cable.

Materials:
Steel and glass.

Finish:
Brushed Brass with
Clear sculptured glass.

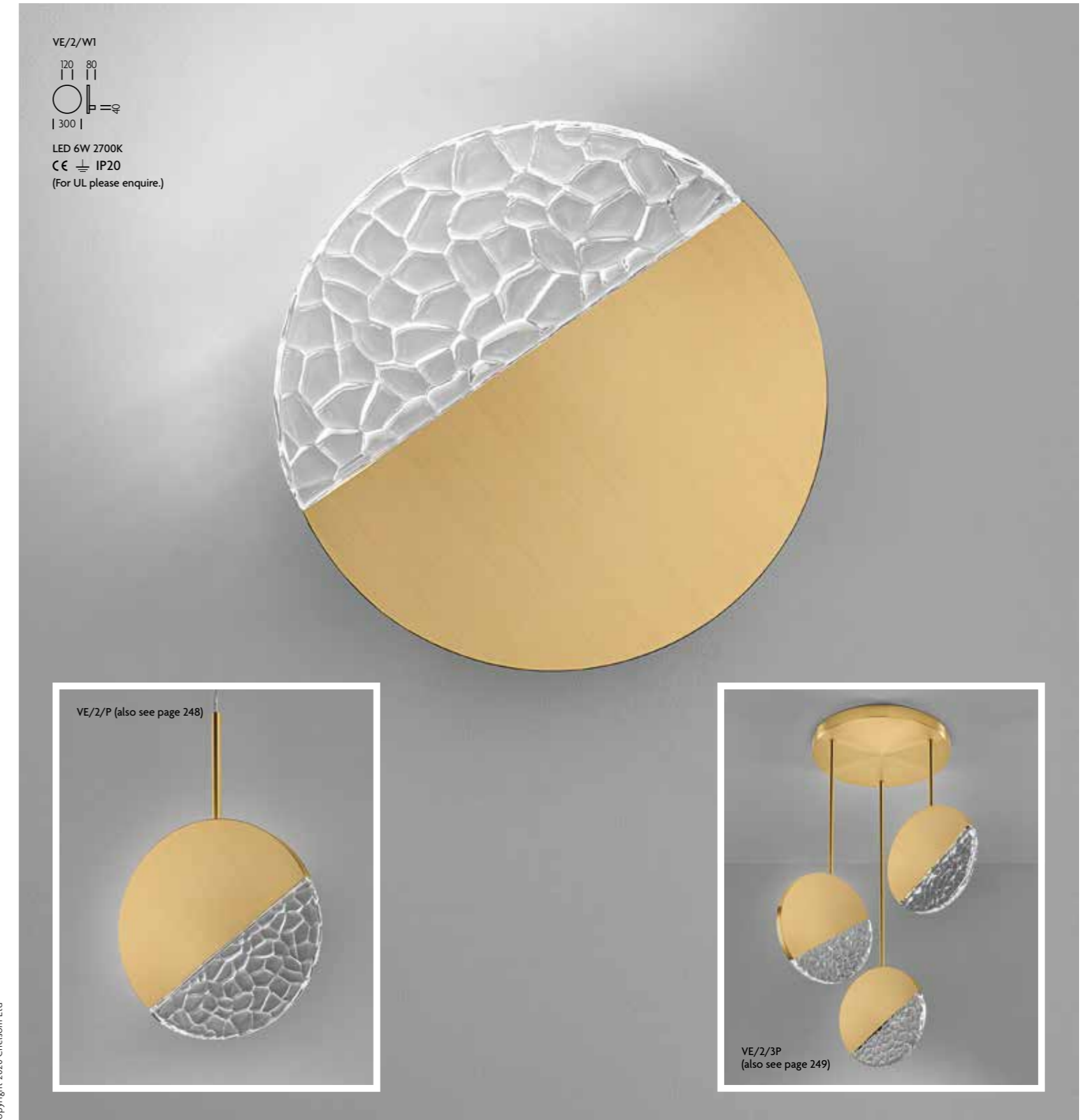

VE/2/W1
120 80
300 |
LED 6W 2700K
CE U L IP20
(For UL please enquire.)

VE/2/P (also see page 248)

VE/2/3P
(also see page 249)

Copyright 2020 Chelsom Ltd

FEATURE WALL LIGHTS

Features: Wall lights suitable for bedside or corridor use. PB/50/BN gives up and down light and PB/70/W1/BN emits a soft light through the frosted polycarbonate diffuser.

Materials:
Steel with frosted polycarbonate on PB/70/W1/BN.

Finish:
Brushed Nickel (BN).



CUBE

Features: A simple but effective public area wall light giving a defined up and down light pattern onto walls. The products can be used individually or grouped to make a dramatic decorative light effect. Drivers are integral.

Materials:
Aluminium and steel.

Finishes:
Brushed Gold with White interior (BRG/W), Black with White Interior (BL/W), or Soft White with White interior (SW/W).

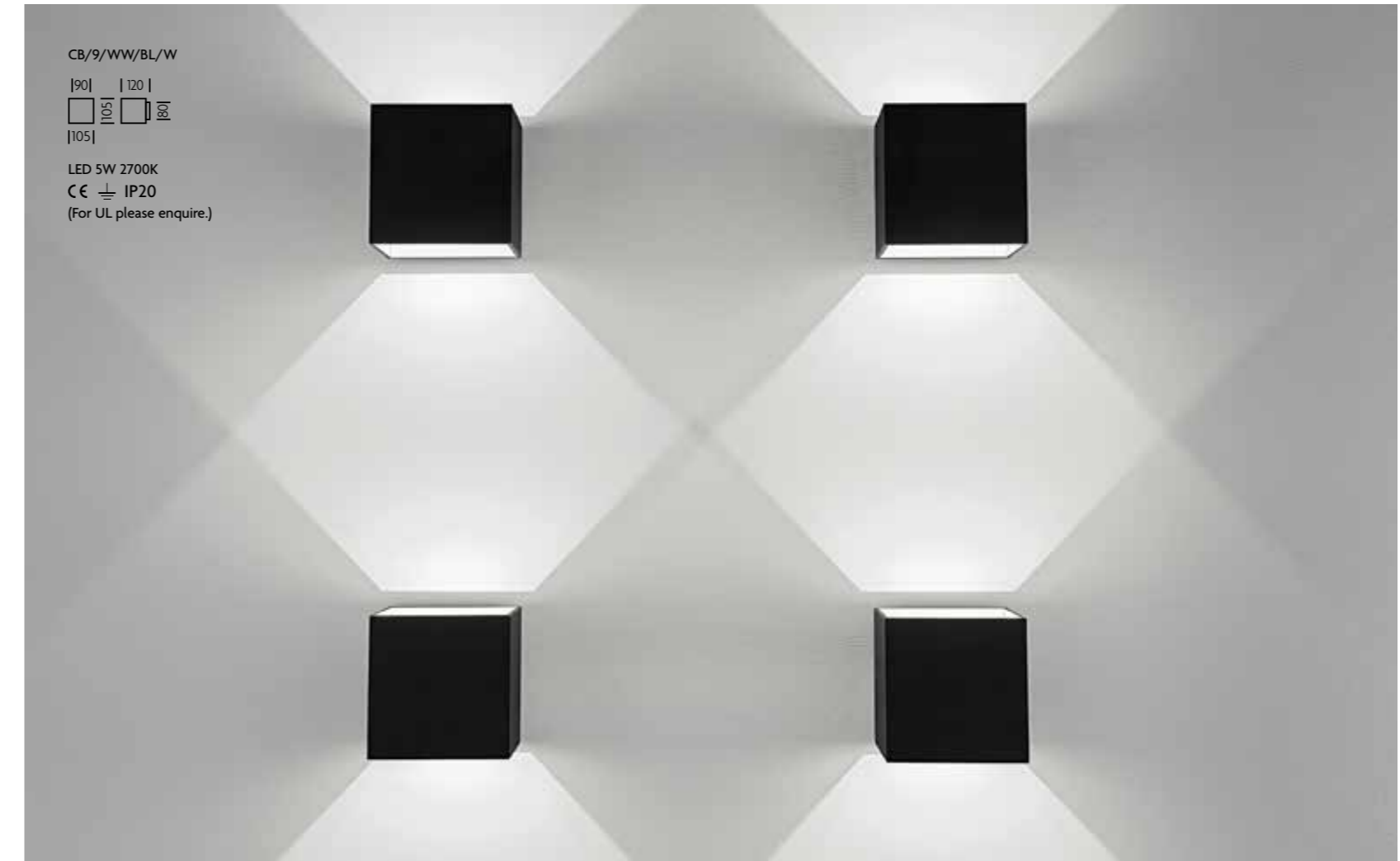

SOLAR

Features: Heavy circular glasses have deep concentric rebates creating a light effect of ripples on a pond. Wall lights also give a decorative spill of light onto walls.

Materials:
Steel and glass.

Finish:
Metalwork is finished in
Satin Black with English
Brass accents. Glass is Smoke.



Copyright 2020 Chelsom Ltd

REFLECTOR

Features: Warm white LED light in the central housing glows back off the faceted reflector plate. The wall light is available in two sizes and can also be used as a flush mounted ceiling fitting. Grouped together, wall lights can make a strong decorative statement.

Material:
Steel.

Finish:
Brushed Brass with
Satin Black (BRB).

RR/30/W1L/BRB (wall mounted)

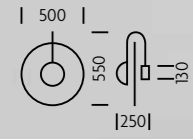

LED 8W 2700K
CE U_L IP20

RR/30/W1/BRB (wall mounted)

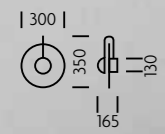

LED 8W 2700K
CE U_L IP20



Project: REFLECTOR at Hotel Indigo London, 1 Leicester Square.
Designer: Michaelis Boyd.



Copyright 2020 Chelsom Ltd

SCONCE

Features: Shade shape creates striking light effect up and down plus reflected light. Shades shown are Black chintz with Brushed Copper lining (BL/COP) or Natural (NAT). Other shade fabrics to special order.

Materials:
Steel metalwork with various fabric options.

Finish:
Satin Black (BL) metalwork.

ROOM NUMBERING

Features: Chelsom are experienced in creating room numbering wall lights for hotel and marine projects. Illustrated are three standard products which can be manufactured to suit customers' quantity and numbering requirements. All prices will be quoted on a project by project basis.

Materials:
Steel and acrylic.

Finishes:
Brushed Brass with faux alabaster for HD/25/W1/RN, Black Bronze with Antique Brass for RN/01, and Satin Black for RN/03.

Project : SCONCE at The Grand Hotel, Lytham St. Annes.
Designer: In-house Design Team.



Copyright 2020 Chelsom Ltd

BROADWAY

Features: Arm rotates left/right and is adjustable for height and reach with two decorative locking key swivel joints. The light source is housed in a ventilated metal shade. There is an integral knurled rotary dimmer switch in the centre of the backplate.

Material:
Steel.

Finishes:
Black Bronze (BB),
Brushed Brass (BRB),
or Polished Chrome (C).



DIRECT

Features: Decorative wooden handle allows rotational movement left and right and there is also a swivel joint above the shade. Shade options include colour matched ventilated metal or fabric – Natural shown here with other options at back of catalogue. Suitable for bedside or desk use.

Materials:
Steel and wood.

Finish:
Black Bronze (BB)
with walnut wood.



PRESTIGE WALL LIGHTS

Features: MD/* models have substantial square section arms and feature outer rectangular or square shades which are Smoke transparent (SM) or Black Chintz with Champagne Gold liner (BG). Inner cylinder shades are Natural Parchment (NP). WT/* wall light has a knurled detail on the column. SG/* model features thick Clear seed glass with internal Hemp (HE). Other shade fabrics available.

Materials:
Steel with glass for SG/25/W1/BB.

Finishes:
Black Bronze with English Brass (BB/EBR) for MD/* and WT/* models, Black Bronze (BB) and Clear seed glass for SG/* model.



TWIST

Features: Hand wrought iron tubing with a distressed patina is formed into a twisted shape and the two arms support offset fabric shades. Shades are bespoke for this product. Other fabrics available.

Materials:
Wrought iron and steel.

Finish:
Florentine Antique Gold Leaf (GO).



KITE

Features: A highly decorative artisan wall light with Florentine Antique Gold 'kites' forming a curved diffuser. The warm glow is reflected onto surrounding surfaces.
THIS MODEL IS PRICED WITH AND COMES COMPLETE WITH LAMP AS SHOWN.

Material:
Steel.

Finish:
Florentine
Antique Gold.

KT/24/200

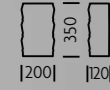

1 x E27 3W LED 2200K
 CE U L IP20



GOLD SCULPTURE

Features: Handmade forged iron sculptural wall lights with an ambient gold leaf finish giving decorative up and down light. See page 304 for matching pendants.

Material:
Hand forged iron.

Finish:
Florentine Antique
Gold Leaf.

SS/80/W1/GO

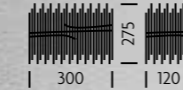

1 x E27 7W LED 2700K
 CE U L IP20

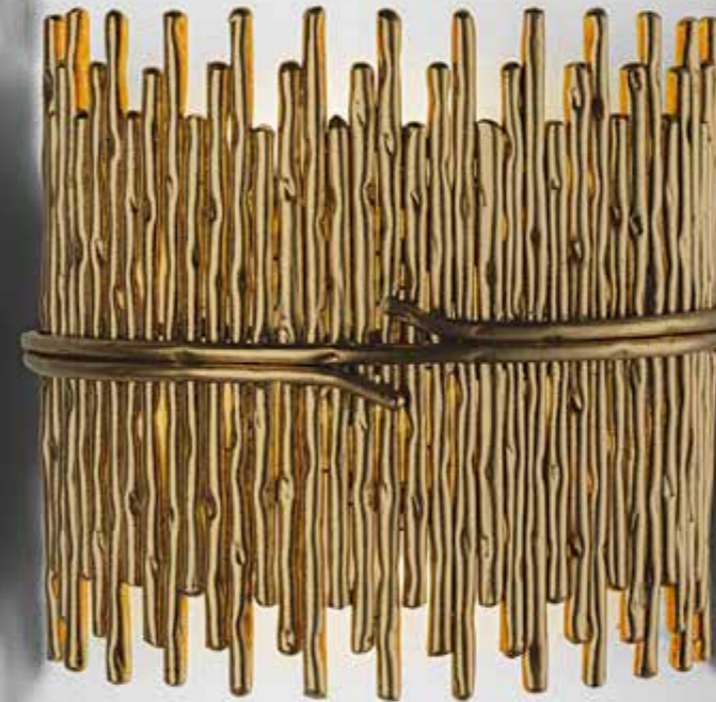

SS/81/W2/GO

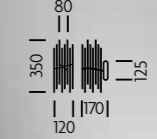

2 x E14 3.5W LED 2700K
 CE U L IP20



Copyright 2020 Chelsom Ltd

PEAR

Features: A tiny point of LED light projects a sparkling glow into sculptured crackle glass pears which then reflect delicate patterns onto the wall. See page 253 for matching pendants.

Materials:
Steel and glass.

Finish:
Brushed Brass with
Clear crackle glass.



CLASSIC Exterior

Features: A classical exterior wall light with a nickel plated internal reflector plate. Front is hinged for maintenance. Clear LED candle lamps recommended.

Material:
Solid cast brass.

Finish:
Bronze.



CLASSIC PICTURE LIGHTS

Features: Detailed backplates and swan neck arms with swivel joints support tubular canopies with anti-glare baffles on the front.

Material:
Steel.

Finishes:
English Brass (EBR) or
Black Bronze (BB).



PL/8/300/EBR

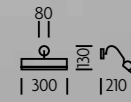

1 x E14 4W LED 2700K

CE U_L IP20

PICTURE LIGHTS

Features: Adjustable slim head with front baffle to prevent glare. Warm white integral LED with frosted diffuser for good light output. Dimming options available for minimum order quantities.

Material:
Steel with acrylic
diffuser.

Finishes:
Black Bronze (BB) or
Polished Chrome (C).



PL/6/300/C

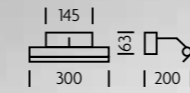

LED 6W 2700K Non-dimmable

CE U_L IP20

(For UL please enquire.)



PL/8/550/BB

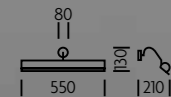

2 x E14 4W LED 2700K

CE U_L IP20



PL/6/550/BB

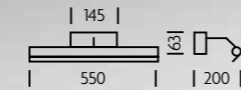

LED 12W 2700K Non-dimmable

CE U_L IP20

(For UL please enquire.)

WALL

The Wall Lights here are from Collections illustrated elsewhere in the catalogue and page cross references are shown.



AS/36/W1/BRB. See page 37 for full range and details.



HY/77/W1/BL. See page 40 for full range and details.



DY/100/W1/BRB/BL. See page 42 for full range and details.



PH/05/W1. See page 51 for full range and details.



BT/8/W1. See page 52 for full range and details.



PP/12/W1. See page 53 for full range and details.



LX/6/WW. See page 44 for full range and details.



HQ/16/W1. See page 46 for full range and details.



CZ/30/W1. See page 48 for full range and details.



RI/23/W1/BRB. See page 54 for full range and details.



SX/48/W1. See page 55 for full range and details.



CA/12/W2. See page 56 for full range and details.

Copyright 2020 Chelsom Ltd

WALL

The Wall Lights here are from Collections illustrated elsewhere in the catalogue and page cross references are shown.



CK/6/W1. See page 57 for full range and details.



SI/23/W1/BL. See page 58 for full range and details.



DI/36/W1. See page 61 for full range and details.



TY/10/W1. See page 72 for full range and details.



CP/24/W1/BRB. See page 74 for full range and details.



TQ/100/W1. See page 75 for full range and details.



LN/34/W1/BRB. See page 64 for full range and details.



RM/9/W1. See page 66 for full range and details.



RA/4/W1. See page 68 for full range and details.



SH/60/W2/BB/EBR. See page 76 for full range and details.



BC/22/W1/BB/EBR. See page 78 for full range and details.



BX/44/W1. See page 92 for full range and details.

Copyright 2020 Chelsom Ltd

CEILING



The Chelsom Value Award is given to ranges which represent exceptional value alongside high design and quality standards.



Eternity 244



Glacier 246



Vetro 248



Icicle 250



Snap 280



Atlanta 281

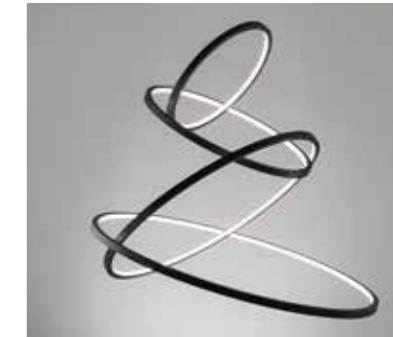

Rings 282



Galaxy 284



Pear 253



Halo 254



Regent 256



Aura 257



Custom Rods 286



Ailsa 288



Space 290



Boom 293



Constellation 258



Diffuse 260



Café 261



Hollywood 262



Brunch 294



Apollo 295



Feature Pendants 297



Pendants 298



Shield 265



Orb 266



Criterion 268



Oxford 270



Bubbles 299



Laguna Pendants 300



Silver/Gold Sculpture 302



Palm 306



Royale 272



Belvedere 274



Windsor 276



Arcade 278



Artichoke 308



Fiji 310



Welcome 312



Mayfair Lanterns 314

Copyright 2020 Chelsom Ltd

ETERNITY

Features: Shallow double rings of high quality Clear crystal prisms refract the concealed LED uplighting to give a nicely muted sparkle. Substantial metal frames which pin the crystal top and bottom ensure the individual crystals are securely fixed and always orientate correctly. Flush fitting has three fixings and comes with a remote driver. The pendant has an integral driver in the ceiling plate and the individual tiers can be adjusted during installation to suit clients' wishes.

Materials:
Steel with
crystal.

Finish:
Brushed
Brass with
Clear crystal.



ET/7000/800F

800
180
Weight 13kg

LED 14W 2700K
CE IP20
(For UL please enquire.)



ET/7000/3P

275
1000 Max Diam
Weight 48kg

Min 1000 / Max 2000

LED 51W 2700K
CE IP20
(For UL please enquire.)

GLACIER

Features: A most dramatic light effect is achieved when fine points of warm LED light shine through the individual random crystal shards and refract off the bevelled edges. The smaller pendant has a fixed rod suspension and the larger hangs from four strainer wires which may be adjusted for height during installation. The substantial wall light sits on a rectangular backbox.

Materials:
Steel and
crystal.

Finish:
Golden Bronze
with Clear crystal.



VETRO

Features: Slim Brushed Brass discs conceal dimmable warm LED light which projects into the thick sculptured glass dramatically illuminating the moulded pattern and the outer perimeter. VE/2/3P is supplied with fixed suspension rods plus three connectable 500mm rods to allow a variety of lengths and VE/2/P hangs on a clear cable.

Materials:
Steel and glass.

Finish:
Brushed Brass with
Clear sculptured glass.



ICICLE

Features: Dimmable integral LED light sources in the base of the glass icicles throw light upwards giving a warm ambient glow whilst reflecting off the tiny silver leaf flecks within the handmade glass (single pendant non-dimmable). Alternate arms curve upwards or downwards. IC/24/P gives a warm downlight glow.
Note: Glass icicles are handmade and may have slight variations. See additional chandelier on page 252.

Materials:
Steel and glass.

Finish:
English Brass with silver-flecked Clear glass.



Copyright 2020 Chelsom Ltd

ICICLE

Features: Dimmable integral LED light sources in the base of the glass icicles throw light upwards giving a warm ambient glow whilst reflecting off the tiny silver leaf flecks within the handmade glass. Alternate arms curve upwards and downwards. Note: Glass icicles are handmade and may have slight variations. See additional models on pages 250-251.

Materials:
Steel and glass.

Finish:
English Brass with silver-flecked Clear glass.



IC/24/12+6
230
Min 1150 / Max 3030
1200
Weight 35kg
18 x LED 3W 2700K
CE IP20
(For UL please enquire.)

PEAR

Features: Tiny points of LED light project a sparkling glow into sculptured crackle glass pears. The single pendant, five light cluster and wall light are illustrated and large custom cascades or spirals are available to special order.

Materials:
Glass and steel.

Finish:
Brushed Brass with Clear crackle glass.



PX/14/5P
400
Min 250 / Max 3000
Weight 5kg
5 x LED 3W 2700K
CE IP20
(For UL please enquire.)

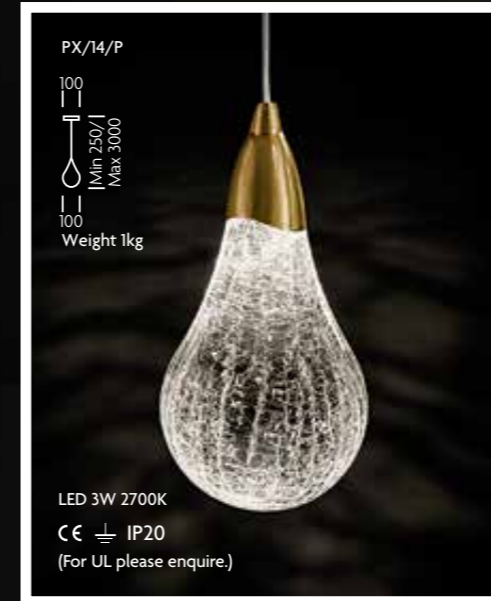

PX/14/P
100
Min 750 / Max 3000
100
Weight 1kg
LED 3W 2700K
CE IP20
(For UL please enquire.)



PX/14/W1 (also see page 234)

HALO

Features: Decorative LED filament lamps reflect a warm glow off the interiors of Brushed Brass rings. The rings on the four and eight light chandeliers can rotate at the end of the arms to give a random appearance. The ten light has rings suspended on black silk-covered cable to look similarly random. HA/100/W1A can be installed with the ring mounted vertically or horizontally. **THE RANGE IS PRICED WITH AND COMES COMPLETE WITH LAMPS AS SHOWN.**

Material:
Steel.

Finish:
Brushed Brass
with Satin Black.



Copyright 2020 Chelsom Ltd

REGENT

Features: Dimmable integral LED light sources shine light upwards into heavily Frosted glass candles which are seen through sparkling Clear glass outer chimneys (wall light non-dimmable). The glass chimneys sit in hexagonal cups and have delicate metal top caps.

Materials:
Steel and glass.

Finishes:
English Brass (EBR) or
Black Bronze (BB) with
Clear and Frosted glass.



AURA

Features: A curved Brushed Brass ring conceals LED points of light which shine outwards illuminating individual faux rock crystals to give a highly ambient light effect. The ceiling fitting is suspended from fine strainer wires adjustable for height during installation and the wall light can be mounted horizontally or vertically.

Materials:
Steel and resin.

Finish:
Brushed Brass.



Copyright 2020 Chelsom Ltd

CONSTELLATION

Features: Ceiling fittings with an organic design giving a random pattern of arms and matt Opal globes. Glasses have threaded inserts to screw on for a durable fixing. Custom designs and sizes can be manufactured.

Materials:
Steel and glass.

Finish:
Brushed Brass with
matt Opal glass.

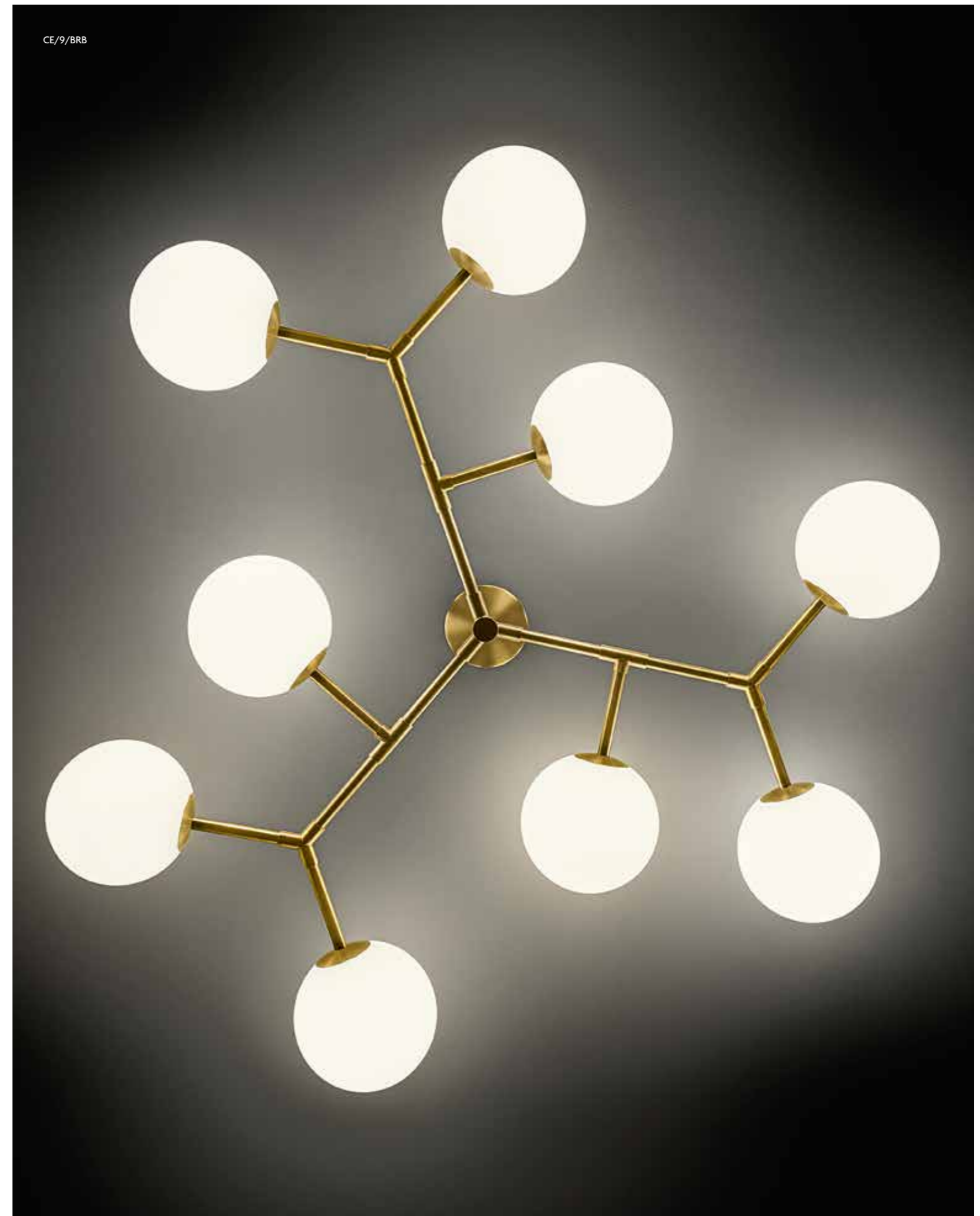

Copyright 2020 Chelsom Ltd

DIFFUSE

Features: Heavy moulded cross-hatched Clear glass diffuses the light into a warm ambient glow. Metalwork is soft Brushed Brass with Satin Black banding. See pages 60 and 61 for full collection. **THE RANGE IS PRICED WITH AND COMES COMPLETE WITH LAMPS AS SHOWN.**

Materials:
Steel and glass.

Finish:
Brushed Brass with Satin Black and Clear glass.



CAFÉ

Features: A decorative public area pendant with three drop rods supporting randomly positioned arms which can be adjusted with detailed locking keys. The globes are deeply ribbed to give a nice ambient glow.

Materials:
Steel and glass.

Finish:
Satin Black with Brushed Brass and matt Opal glass.



Copyright 2020 Chelsom Ltd

HOLLYWOOD

Features: Deep circular brass frames have faux alabaster acrylic diffusers emitting an ambient downwards glow of warm LED light. Chandeliers have heavy suspension rods and detailed centre plates.

Materials:
Steel with acrylic diffusers.

Finish:
Brushed Brass with faux alabaster.



Copyright 2020 Chelsom Ltd

RADAR

Features: Shallow perforated metal coolie shades are supported by detailed knurled lampholder covers and contain LED squirrel cage filament lamps. RA/5/W1 has a directional head. RA/4/W1 can be ceiling mounted. See page 68 for matching table lamp. **THE RANGE IS PRICED WITH AND COMES COMPLETE WITH LAMPS AS SHOWN.**

Material:
Steel.

Finish:
English Brass with
Satin Black.



RA/4/P
100
Min 250/1
Max 2000
270
Weight 1kg
1 x E27 3W LED 2200K
CE U_L IP20



RA/5/W1
230
315
1 x E27 3W LED 2200K
CE U_L IP20

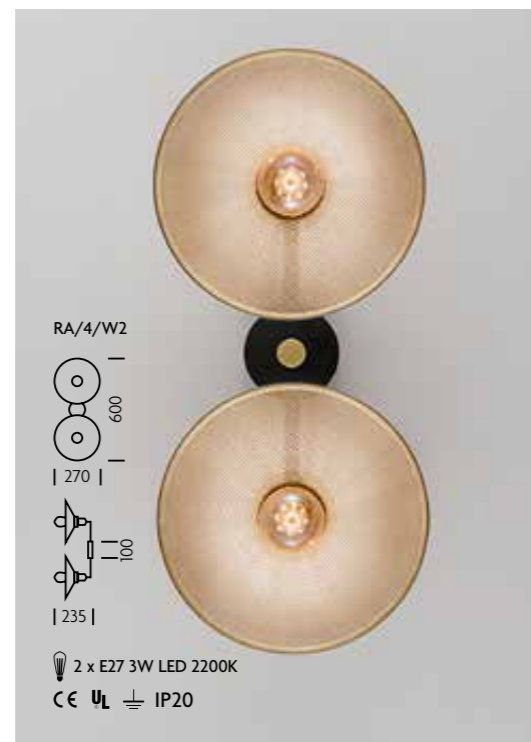

RA/4/W2
600
270
100
235
2 x E27 3W LED 2200K
CE U_L IP20



RA/4/W1
270
220
1 x E27 3W LED 2200K
CE U_L IP20

SHIELD

Features: The Shield chandelier has perforated metal conical shades giving a warm glow through Opal acrylic liners. The half shade on the wall light throws light onto the oval backplate creating a halo effect around its concave curved perimeter. 2500K filament lamps recommended.

Material:
Steel.

Finish:
Golden Bronze
with Satin Black.



SF/29/W1 (also see page 215)

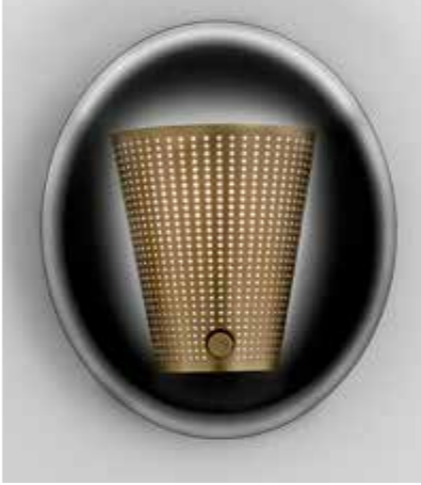

SF/29/8
120
Min 500/
Max 2350
1000
Weight 11kg
8 x E27 6W LED 2500K
CE U_L IP20

Copyright 2020 Chelskom Ltd

ORB

Features: Matt Opal globes have a screw connection into Brushed Brass bowls which are perforated with a houndstooth pattern allowing spills of light to shine through. These are supported by curved arms extending from substantial Brushed Brass rings. Chandeliers hang on three stainer wires adjustable for height during installation.

Materials:
Steel and glass.

Finish:
Brushed Brass with
Satin Black and
matt Opal glass.



Copyright 2020 Chelsom Ltd

CRITERION

Features: Dimmable integral LED light sources sparkle and refract through individual solid clear glass rods. Faux alabaster acrylic bottom diffusers give a soft downlight.

Materials:
Glass and steel with acrylic diffusers.

Finishes:
Polished Brass (PB) or Polished Chrome (C) with faux alabaster.



Copyright 2020 Chelsom Ltd

OXFORD

Features: Simple elegant sweeping arms with matt Opal or Clear Crackle glass globes are equally at home in a traditional or contemporary setting. Glasses have integral threaded metal fixings for secure attachment. Wall lights can be installed as up or down lights. **WHEN SUPPLIED WITH CLEAR CRACKLE GLASSES, THE FITTINGS ARE PRICED WITH AND COME COMPLETE WITH LAMPS AS SHOWN.**

Materials:
Steel and glass.

Finishes:
Brushed Brass (BRB) with glasses in matt Opal (OP) or Clear Crackle (CR).



OX/42/3/BRB with optional glass GS/200/OP

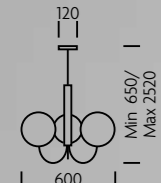

Weight 5kg

1 x E27 7W LED 2700K

CE U_L IP20



OX/42/6/BRB with optional glass GS/200/CR

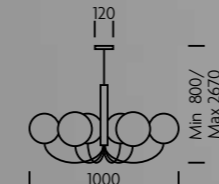

Weight 8kg

6 x E27 3W LED 2200K

CE U_L IP20



OX/42/W1/BRB with optional glass GS/200/OP

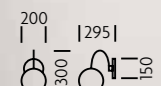

1 x E27 7W LED 2700K

CE U_L IP20



OX/42/W1/BRB with optional glass GS/200/OP

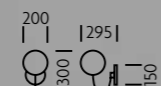

1 x E27 7W LED 2700K

CE U_L IP20



OX/42/W2/BRB with optional glass GS/200/CR

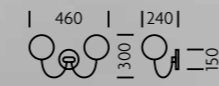

2 x E27 3W LED 2200K

CE U_L IP20



OX/42/P/BRB with optional glass GS/200/CR

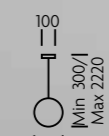

Weight 1.8kg

1 x E27 3W LED 2200K

CE U_L IP20

ROYALE

Features: Extremely heavy rectangular brass section tubing is formed into a detailed cartwheel pattern which exudes quality. The subtle Brushed Brass adds warmth and various shade options are shown. Wall light backplates replicate the circular shapes.

Material:
Steel.

Finish:
Brushed Brass.



Copyright 2020 Chelsom Ltd

BELVEDERE

Features: A collection of chandeliers and wall light which are transitional in design featuring reeded columns and knurled lampholder covers. A range of optional shade fabrics are shown and the three-armed chandelier, BV/6/3, has an optional single shade for guestroom, corridor or public space.

Material:
Steel.

Finish:
Golden Bronze
with Satin Black.



Copyright 2020 Chelsom Ltd

WINDSOR

Features: Stylish sweeping arms come together in a stepped chunky centre body. Heavily ribbed Veneto mouth blown tulip glasses in matt Opal or Smoke finish are fixed with lampholder shade rings. **WHEN SUPPLIED WITH SMOKE GLASSES, THE FITTINGS ARE PRICED WITH AND COME COMPLETE WITH LAMPS AS SHOWN.**

Materials:
Steel and glass.

Finishes:
Brushed Brass with glass in Smoke (SM) or matt Opal (OP).



Copyright 2020 Chelsom Ltd



ARCADE

Features: Dimmable integral LED light sources give ambient light through perforated metal frames with soft diffused downlight from Opal acrylic diffusers. Wall light has diffusers top and bottom.

Materials:
Steel and acrylic.

Finish:
Golden Bronze metalwork with matt Opal acrylic.

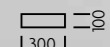
AD/35/FF

 | 300 |
 Weight 1.85kg
 LED 10W 2700K
 CE \neq IP20
 (For UL please enquire.)

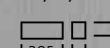

AD/35/WW

 | 285 |
 | 100 |
 LED 8W 2700K
 CE \neq IP20
 (For UL please enquire.)



AD/35/FF2

 | 600 |
 | 300 |
 Weight 8kg
 LED 20W 2700K
 CE \neq IP20
 (For UL please enquire.)



Copyright 2020 Chelsom Ltd

SNAP



Features: Fabric shades 'snap on' to backplates or ceiling plates for ease of installation and maintenance.

Materials:
Steel frames with fabric diffusers.

Finish:
Natural fabric with Oyster bottom diffusers on flush fittings.



ATLANTA

Features: Semi-flush ceiling fittings have matt Opal acrylic diffusers and off white textured cotton fabric shades.

Materials:
Steel, acrylic and fabric.

Finishes:
Brushed Brass (BRB) or Polished Chrome (C).



Copyright 2020 Chelsom Ltd

RINGS

Features: Ultra thin metal rings emit warm LED light through interior Opal acrylic diffusers. Rings are suspended on adjustable strainer wires with control gear housed in ceiling plate. Options include a single tier as well as three tier and four tier pendants. Custom options are available at special request.

Materials:
Steel and acrylic diffusers.

Finish:
Satin Black with Opal acrylic.



RS/10/3TIER

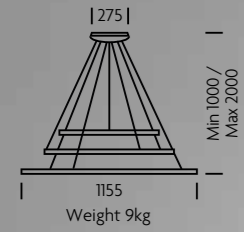

LED 69W 2700K
CE \pm IP20
(For UL please enquire.)



RS/10/855

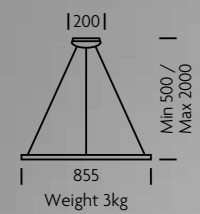

LED 21W 2700K
CE \pm IP20
(For UL please enquire.)

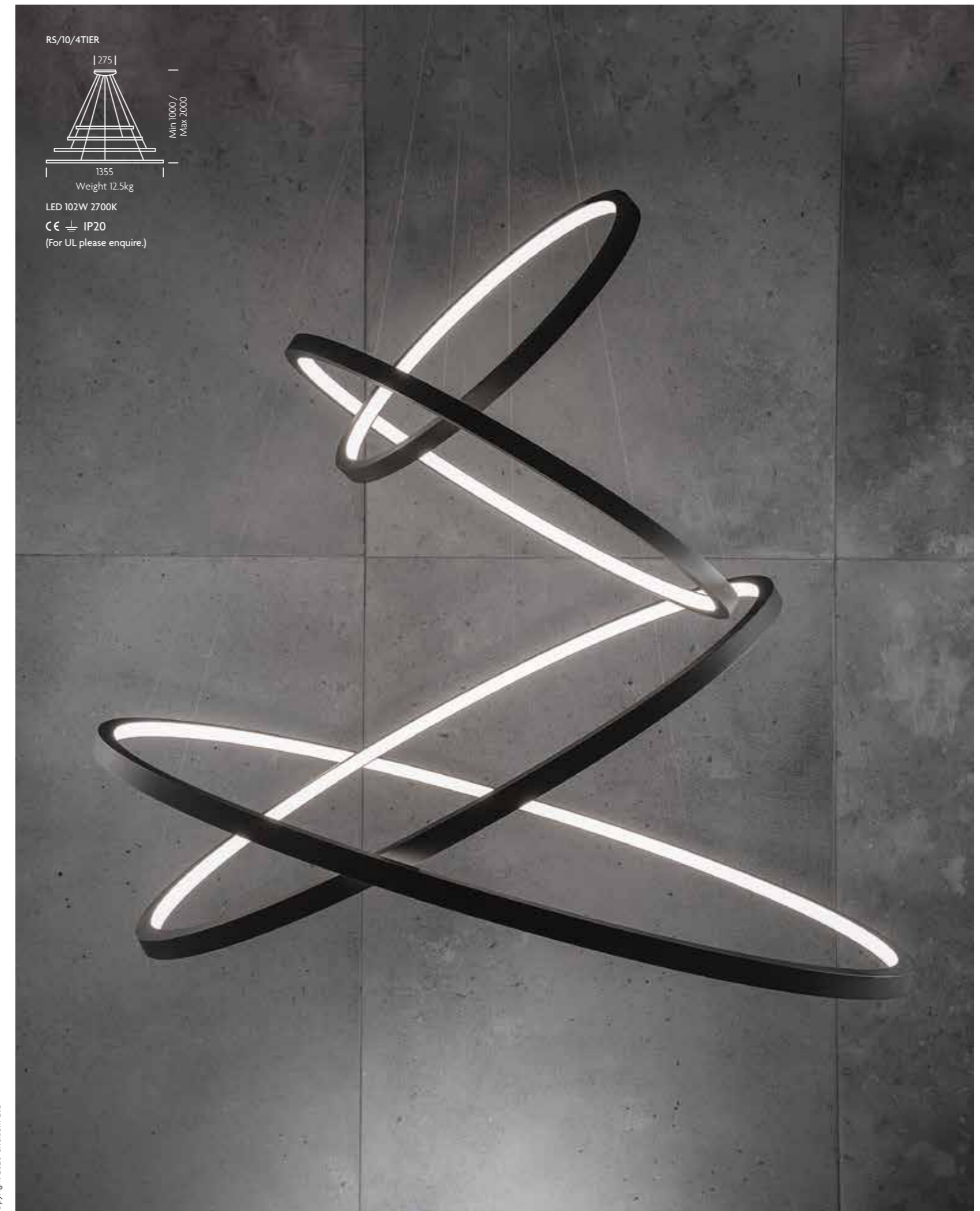

RS/10/4TIER

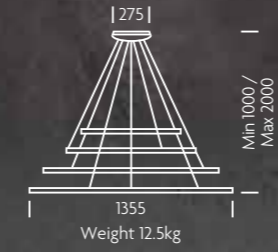

LED 102W 2700K
CE \pm IP20
(For UL please enquire.)

GALAXY

Features: Shallow flat rings support frosted acrylic diffusing cylinders giving warm LED light. Single tier and three tier versions are shown. Heights can be adjusted during installation through the suspension strainer wires and control gear is housed in the ceiling plates.

Materials:
Steel and acrylic.

Finish:
Penny Bronze with frosted acrylic.

GX/102/600/18

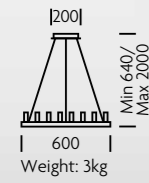

LED 18W 2700K

CE \neq IP20
(For UL please enquire.)



GX/102/1000/30+24+18

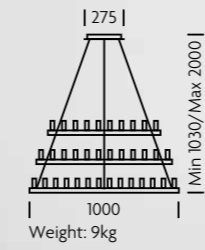

LED 72W 2700K

CE \neq IP20
(For UL please enquire.)



Custom RODS

Features: A lighting concept allowing clients to create their own custom designs in any finish and virtually any shape, size or number of tiers can be created. Rods are screwed into the metalwork. Each rod is illuminated from above with a warm white LED light source which sparkles at the bottom of the rod and through the bubbles inside where applicable. Individual rod pendants are also available as are fixed suspension versions. Various rod diameters and lengths are available.

Materials:
Steel and acrylic.

Finishes:
Metal – Off White and Brushed Nickel for single pendant.



Project: CUSTOM RODS at Crowne Plaza Reading.
Designer: ADS Design.

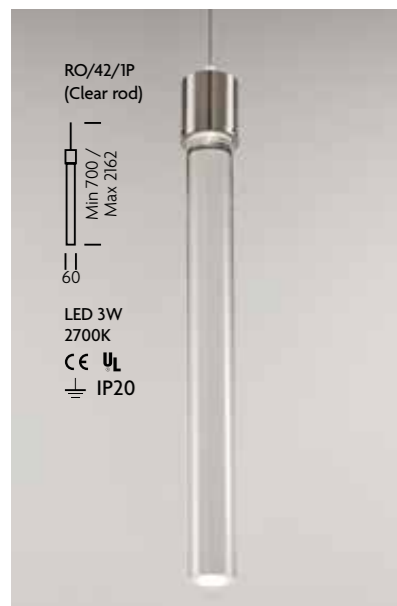

Custom FILAMENT

Features: These ambient and decorative LED 3W warm white dimmable filament lamps are the main feature of the Custom Filament range. A two tier pendant and installations are shown below. Steel frames can be virtually any finish and diameter with any other shapes and sizes to clients' specification. Please contact Chelsom with your ideas and concepts.

Material:
Steel.

Finish:
Penny Bronze shown.



Project: CUSTOM FILAMENT at Castle Hotel Windsor – MGallery by Sofitel.
Designer: Trevillion Interiors.



Project: CUSTOM FILAMENT at Mercure Bristol North The Grange Hotel.
Designer: Helen Hooper Interiors.

Copyright 2020 Chelsom Ltd

AILS A

Features: Opal acrylic top diffusers prevent dust and insect ingress and lift out for cleaning and maintenance.

Materials:
Steel with cottonette fabric and acrylic diffusers.

Finish:
Penny Bronze with Oyster fabric diffusers.

Project: AILSA at Swissôtel The Bosphorus, Istanbul.
Designers: KCA International.



Copyright 2020 Chelsom Ltd

SPACE

Features: High light output from architectural fittings to illuminate public spaces.
Options available include special sizes, dimming, integral emergency lighting, mesh covers for open bowls to prevent dust and insect ingress and special metal colour finishes.

Materials:
Steel frames with acrylic diffusers.

Finish:
Steel Grey painted metalwork with Opal acrylic.

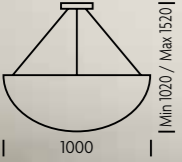

SA/28/900/P

 1000
 Weight 15kg
 6 x E27 7W LED 2700K
 CE U_L IP20

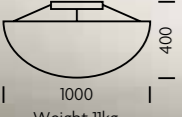

SA/28/900/F

 1000
 Weight 11kg
 6 x E27 7W LED 2700K
 CE U_L IP20



SA/29/600/P

 680
 Weight 13kg
 3 x E27 7W LED 2700K
 CE U_L IP20

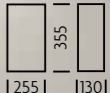

SA/30/W2

 255 | 130
 2 x E27 7W LED 2700K
 CE U_L IP20

Copyright 2020 Chelsom Ltd

Custom DIAMOND

Features: A strong geometric diamond frame suspends Black chintz cylinder shades with a Gold Herringbone pattern inside to give a warm and decorative ambient glow. Alternative finishes, larger sizes, different shapes and shade options available. Please contact Chelsom with your ideas and concepts.

Material:
Steel.

Finish:
Satin Black.



DM/87/6 with optional shades QCY/14/BL/GHB

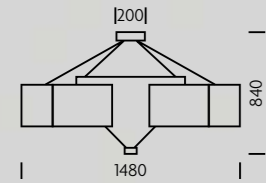

6 x E27 7W LED 2700K
CE UL IP20



Project: CUSTOM DIAMOND at The Grand Hotel, Lytham St. Annes.
Designer: In-house Design Team.

BOOM

Features: Two gently curving triangular Satin Black panels enclose the light source which gives a warm ambient glow from the Brushed Brass interior. The pendant is supplied with a fixed suspension rod which can divide into three connectable parts (250mm, 400mm and 600mm). **THE RANGE IS PRICED WITH AND COMES COMPLETE WITH LAMPS AS SHOWN.**

Material:
Steel.

Finish:
Satin Black with Brushed Brass.



BM/56/P

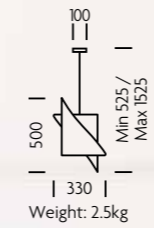

2 x E14 3.5W LED 2100K
CE UL IP20

BM/56/W2 (also see page 214)



BRUNCH

Features: Hand spun metal shades have detailed rolled edges and good light output from white interiors. Pendants are suspended with black silk-covered cable.

Material:
Steel.

Finishes:
Brushed Brass with Satin Black accents (BRB) or Satin Black (BL).

BH/40/P/BRB

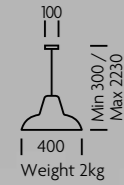

1 x E27 7W LED 2700K
CE U L IP20



BH/40/P/BL



BH/40/W1/BL (also see page 217)



APOLLO

Features: Matt Opal glass globes are centred within shallow cones which reflect the warm glow.

Materials:
Steel and glass.

Finish:
Brushed Brass with matt Opal glass.

AO/007/P

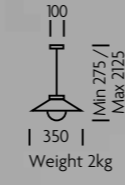

1 x E14 3W LED 2700K
CE U L IP20



AO/007/W1 (also see page 216)

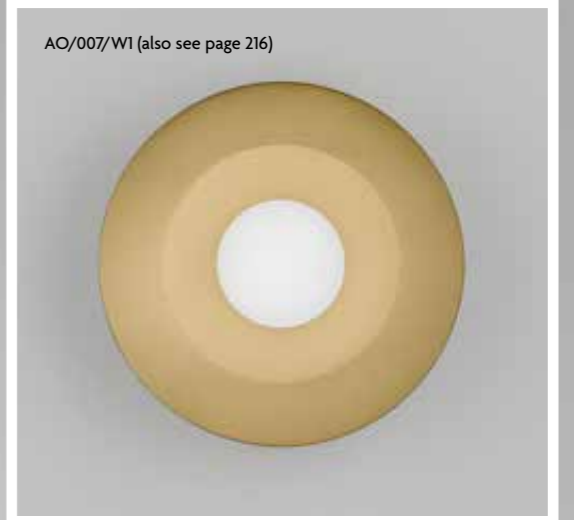

CAPRI

Features: Heavily ribbed matt Opal glass shades are secured onto knurled decorative double-stepped caps. Light sources are dimmable. CP/24/P has a fixed suspension rod which can divide into three connectable parts (250mm, 400mm or 600mm). See page 74 for matching table and wall lights.

Materials:
Steel and glass.

Finishes:
Brushed Brass (BRB) or Black Bronze (BB) with matt Opal glass.



FEATURE PENDANTS

Features: Decorative ambient pendants featuring deeply ribbed matt Opal retro shapes or striking Snowflake glass globes.

Materials:
Glass and steel.

Finishes:
Matt Opal glass with English Brass or Snowflake glass with Brushed Brass for TQ/* models.



Copyright 2020 Chelsom Ltd

PENDANTS



Features: Supplied with Polished Chrome suspension units except for PE/60/BL/COP which is Brushed Nickel.

Materials:

Duplex glass for DN/20 models, steel for DN/125/C and DN/35/BL, fabric for PE/60.

Finishes:

DN/20/W – Opal. DN/20/BL – Black/Opal. DN/35/BL – Black/White. DN/125/C – Chrome/White. PE/60/BL/COP – Black/Copper.



BUBBLES

Features: Mouthblown heavy matt Opal glass gives a soft diffused light and is secured with Brushed Brass ceiling plates. The two sizes can be grouped together for a decorative effect as in the image below. Both sizes are also suitable for wall mounting.

Materials:
Steel and glass.

Finish:
Matt Opal glass with Brushed Brass.



LAGUNA Pendants

Features: Rediscovered artisan glass moulds which had lain unused since the 1960s create stunning geometric patterned mouthblown glass pendants. Suspension units have knurled detailing. **PRODUCTS ARE PRICED WITH AND COME COMPLETE WITH LAMPS AS SHOWN.**

Materials:
Glass with steel.

Finishes:
Olive glass with Black Bronze metalwork and Black silk-covered cable or Mocca glass with Golden Bronze metalwork and Black silk-covered cable.



LG/3P/OLIVE

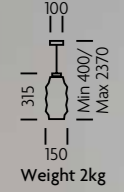

Weight 2kg

1 x E27 4W LED 2200K

CE U_L IP20

LG/3P/MOCCA



LG/5P/OLIVE

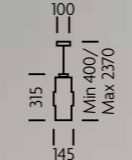

Weight 2kg

1 x E27 4W LED 2200K

CE U_L IP20

LG/5P/MOCCA

SILVER SCULPTURE

Features: Handmade lighting in forged iron with an organic feel.

Material:
Hand forged iron.

Finish:
Florentine Antique
Silver Leaf.

Shades:
Spring clip candle
shades available – see
back of catalogue.

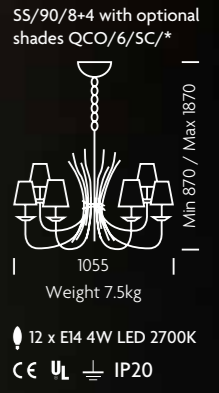
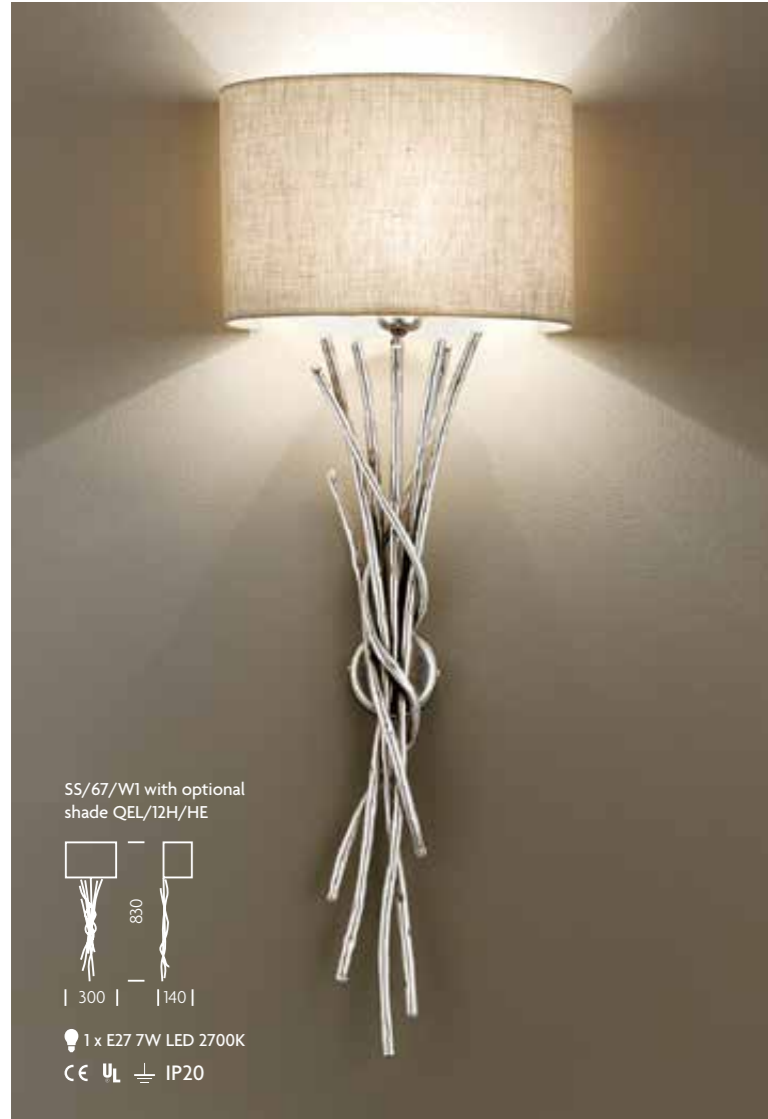

GOLD SCULPTURE

Features: Handmade forged iron sculptural lighting with an ambient gold leaf finish. Both pendants have Opal acrylic bottom diffusers and alternative shade fabrics are available for pendant, SS/21/GO.

Materials:
Hand forged iron with acrylic diffusers.

Finish:
Florentine Antique Gold Leaf.



SS/80/4P/GO

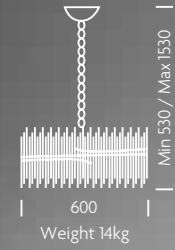

4 x E27 7W LED 2700K
CE UL IP20



SS/80/W1/GO

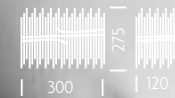

1 x E27 7W LED 2700K
CE UL IP20



SS/81/W2/GO

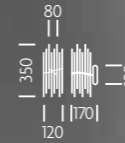

2 x E14 3.5W LED 2700K
CE UL IP20



SS/21/GO



4 x E27 7W LED 2700K
CE UL IP20

Copyright 2020 Chelsom Ltd

PALM

Features: Hand-formed and decorated metal palm leaves allow light to emit through pierced slots as well as giving a warm glow of back light for a highly ambient collection.

Material:
Steel.

Finish:
Florentine Antique
Gold Leaf.



PM/28/W2

| 315 | | 190 |



∅ 2 x E14 3.5W LED 2100K

CE UL IP20



PM/28/800/P



Weight 6kg

∅ 6 x E14 3.5W LED 2100K

CE UL IP20

Project: PALM at Mercure Brighton Seafront Hotel.
Designer: Helen Hooper Interiors.



PM/28/800/P from below



PM/28/650/P

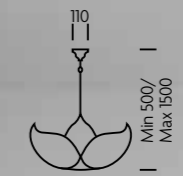

Weight 4.5kg

∅ 6 x E14 3.5W LED 2100K

CE UL IP20

ARTICHOKE

Features: Random curved metal leaves with internal gold leaf to reflect a warm glow.

Materials:
Wrought iron
and steel.

Finish:
Florentine Antique
Gold Leaf.



Project: ARTICHOKE at Darbaar, London.
Designer: Nanu Soda Ltd.

FIJI

Features: Handwoven raffia fabric shades which give an artisan feel with random patterns in the material itself. The raffia is on a frosted PVC backing allowing a diffused view of the globe lamps inside. The shades hang from distinctive twisted natural rope cable. **THIS RANGE IS PRICED WITH AND COMES COMPLETE WITH LAMPS AS SHOWN.**

Materials:
Raffia on PVC.

Finish:
Raffia.

FJ/600/P

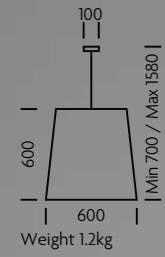

Weight 1.2kg
1 x E27 8W LED 2700K
CE UL IP20



FJ/450/P

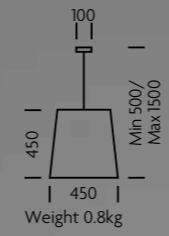

Weight 0.8kg
1 x E27 8W LED 2700K
CE UL IP20



FJ/300/P

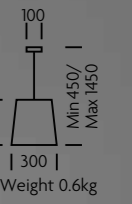

Weight 0.6kg
1 x E27 8W LED 2700K
CE UL IP20



FJ/300/W1

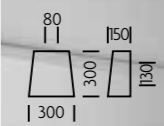

Weight 0.6kg
1 x E27 7W LED 2700K
CE UL IP20



WELCOME

Features: BR/5 is an extremely shallow pendant emitting good light through a fabric outer shade and a matt Opal acrylic diffuser underneath. WE/10 items have fabric shades enclosed by a cruciform top frame which drops down the outside of the shades. WE/10/700 has an internal bottom self-fabric diffuser. Other shade fabrics are available.

Materials:
Steel, with acrylic for BR/5.

Finishes:
Satin Black with matt Opal for BR/5 and Penny Bronze for WE/10 models.



BR/5 with optional shade QBN/600/OY

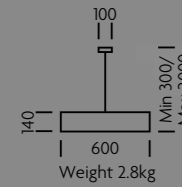

Weight 2.8kg
3 x E27 7W LED 2700K
CE U_L IP20



Project: WELCOME SHADES at The Lowry Hotel, Manchester.
Designer: Goddard Littlefair.



WE/10/700 with optional shade QWE/700/LINEN NAT

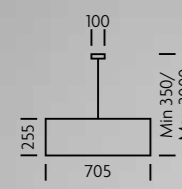

1 x E27 7W LED 2700K
CE U_L IP20



WE/10/200 with optional shade QWE/200/LINEN NAT

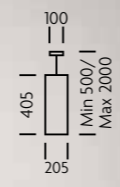

1 x E27 7W LED 2700K
CE U_L IP20



Project: WELCOME SHADES at TWENTY EIGHT, Amsterdam.
Designer: Martin Brudnizki Design Studio.

Copyright 2020 Chelsom Ltd

MAYFAIR Lanterns

Features: Clear LED candle lamps recommended except where optional shades are fitted (MY/122/L/PN).

Materials:
Solid brass, clear glass (frosted glass on request).

Finishes:
Polished Nickel (PN) or subtle Antique Brass (AB).



MY/122/L/PN with optional shades QCO/6/SC/SILK PEBBLE

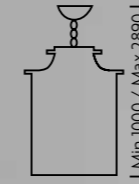

Min 1000 / Max 2890 |

435 |
Weight 14kg

4 x E14 4W LED 2700K
CE U_L IP20



Copyright 2020 Chelsom Ltd

SHADES

Pages 316-319 illustrate the standard Chelsom shade collection showing technical information and fabrics available. Other individual or range specific shades are shown throughout the catalogue and we welcome enquiries for any special shapes, designs or fabrics. Shades are handmade with white epoxy coated three or four strut frames (gold struts when shades have gold lining) and have E27 fixed gimbal as standard.

E14 or spring clip fixings are also available (denoted by model number if standard). Snap-in converter rings are available to change E27 to E14/B22/B15. Wipeable shade fabric is available in White or Off White. Maximum recommended lamp wattages are shown within line drawings. *** Please add colour suffix when ordering (see overleaf).**

QST – SHALLOW TAPERED with frosted acrylic top diffuser with ventilation hole

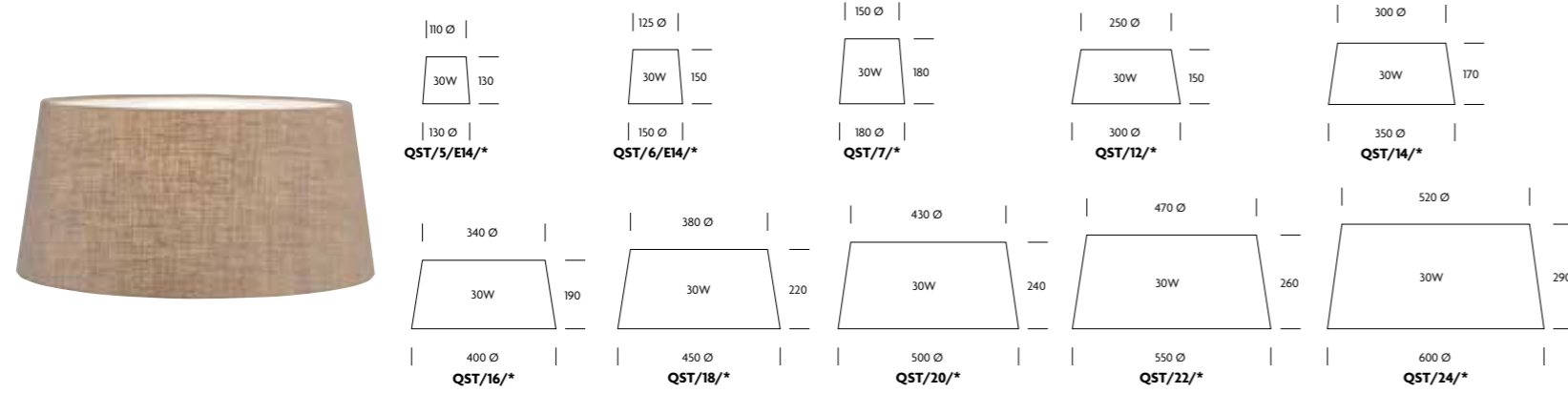

QEL – ELLIPSE

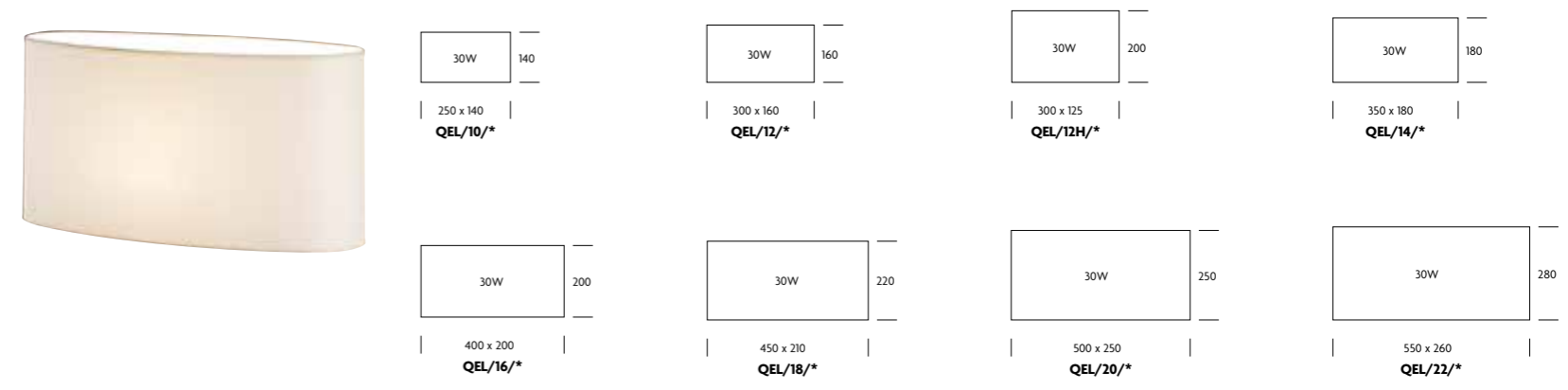

QFD – FRENCH DRUM

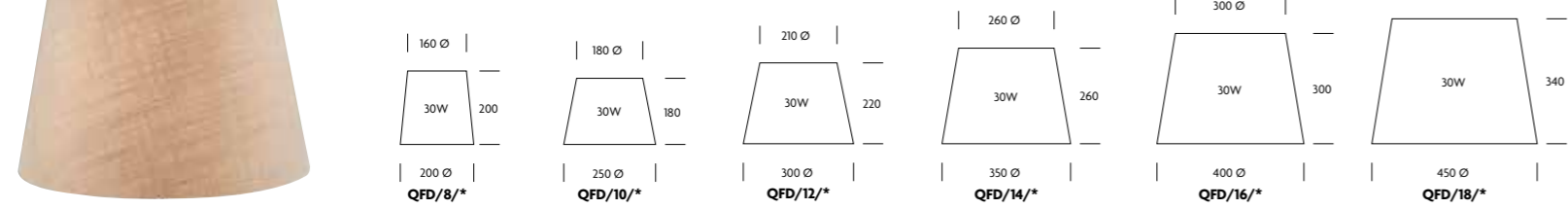

QBR – BOWED RECTANGLE

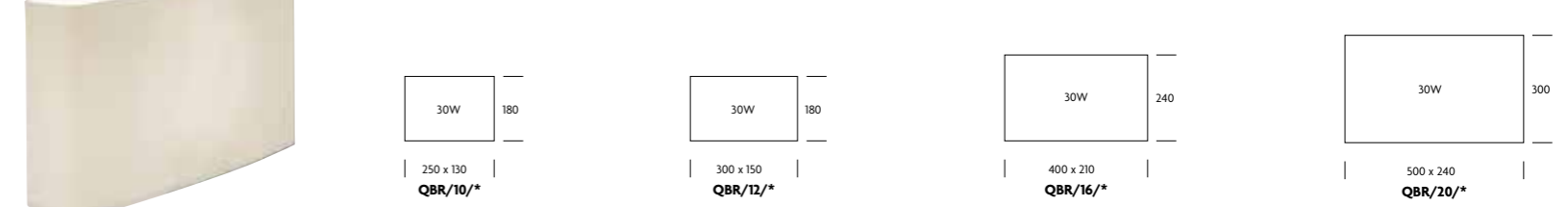

QCY – CYLINDER

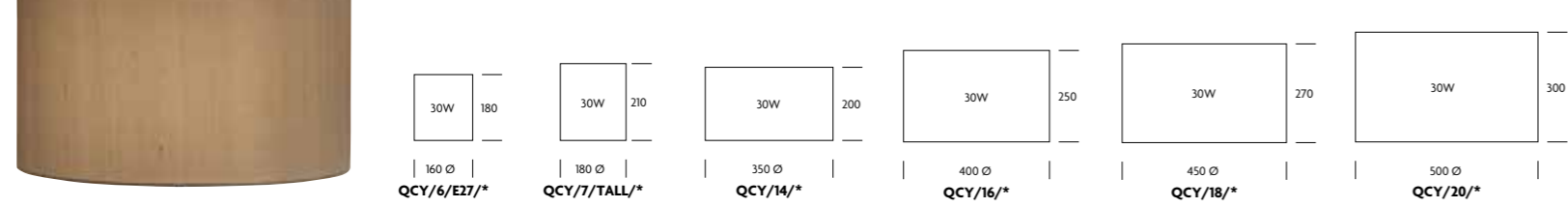

QOB – OBLONG

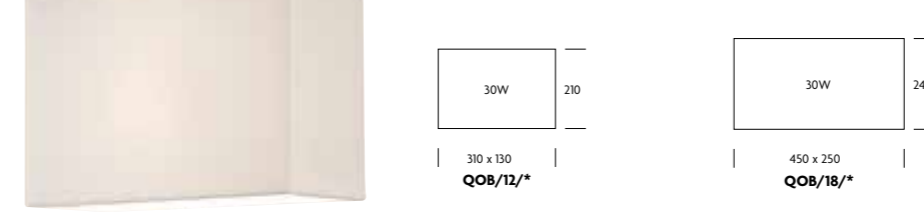

QRTS – ROUNDED TAPERED SQUARE

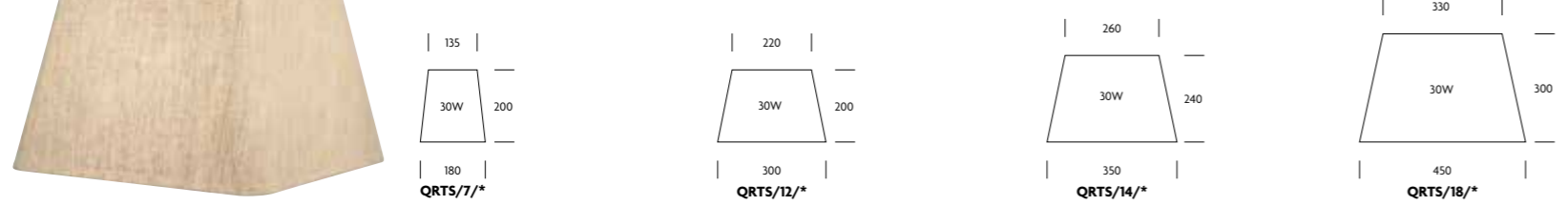

Copyright 2020 Chelsom Ltd

SEE OVERLEAF FOR STANDARD FABRIC AND COLOUR OPTIONS

SHADE FABRIC OPTIONS



Cotton Chintz Oyster
(OY)



Cotton Chintz White
(W)



Cotton Chintz Stone
(ST)



Linen Stone
(LINEN ST)



Hemp
(HE)



Natural
(NAT)



Cotton Chintz Black
(BL)



Cotton Chintz Gunmetal
(GM)



Cotton Chintz Pebble
(PEBBLE)



Satin Pebble
(SATIN PEBBLE)



Pongee Silk Pebble
(SILK PEBBLE)



Pongee Silk Meadow
(SILK MEADOW)



Cotton Chintz Grey with Black Trim
(GRB)



Cotton Chintz Oyster with Grey Trim (OYG)
Also Oyster with Black (OYB) & Oyster with Taupe (OYT)



Cotton Chintz White with Black Trim (WB)
Also White with Grey Trim (WG)



Ivory Pleat
(IVPL)



Black with Gold Lining
(BG)



Black with Silver Lining
(BS)



Cotton Chintz White with Gold Lining
(WGO)



Linen Natural
(LINEN NAT)



Linen Bone
(LINEN BONE)



Black with Copper Lining
(BL/COP)

Copyright 2020 Chelsom Ltd

OTHER FABRICS AVAILABLE TO SPECIAL ORDER

OTHER FABRICS AVAILABLE TO SPECIAL ORDER

TECHNICAL Reference

PRODUCT TECHNICAL SPECIFICATIONS

Every product included in the Edition 27 catalogue is shown with basic dimensions and technical specification. For full technical specification details please visit the Chelsom website www.chelsom.co.uk from where Product Specification Sheets can be downloaded.

TECHNICAL SPECIFICATION KEY

The following symbols or technical comments appear throughout Edition 27.

CE CE Symbol (Conformité Européene)
Denotes compliance with relevant European electrical safety regulations.

UL UL Symbol (Underwriters Laboratory)
Denotes compliance with relevant USA and Canadian electrical safety regulations for lighting products.

I Class I Symbol
Denotes the electrical safety class of the product – earth included.

II Class II Symbol
Denotes the electrical safety class of the product – double insulated, not earthed.

III Class III Symbol
Denotes the electrical safety class of the product – protection against electric shock, supply from safety extra-low voltage (SELV).

IP20 IP20 (Ingress Protection)
Denotes protection against solid objects greater than 12.5mm. No protection against liquids. *Touch proof.*

IP44 IP44 (Ingress Protection)
Denotes protection against solid objects greater than 1.0mm and protection against splashes of water from any angle. *Limited water protection.*

IP65 IP65 (Ingress Protection)
Denotes protection against ingress of dust and protection against low pressure water jets from any angle. *Water resistant.*

ZONE 1 Zone 1 in Bathrooms
The area above that defined by the perimeter of the bath or shower tray.

ZONE 2 Zone 2 in Bathrooms
The area adjoining the bath or shower tray up to a distance of 600mm.

2700K 2700K Colour Temperature
Denotes colour temperature measured in Kelvins (2200K to 3000K within the standard range).

USB USB Symbol
Denotes product which comes with integral USB charging port with 2.0A output.

INTERNATIONAL ELECTRICAL STANDARDS

Chelsom can wire in-house to meet all international standards. Luminaires are constructed and tested to comply with the Electrical Equipment (Safety) Regulations 1994 with reference to BS EN 60598 – 1:2015 and with the applicable BS EN 60598 Part 2 standard. Most of the range has UL approval and almost all luminaires can be wired for 110V or 230V.

LIGHT CALCULATIONS

The experienced Chelsom consultants together with the Technical Manager are pleased to visit site and discuss lighting schemes and light calculations with clients. Either lux level readings can be taken on site or calculations can be made at Head Office from architects' drawings and plans. Advice can be given on the location, quantity and type of light sources required.

EMERGENCY LIGHTING

Whether emergency lighting is required within individual luminaires or is installed remotely, Chelsom are knowledgeable in all aspects of emergency lighting requirements. Please contact the Technical Team to discuss legal requirements and how those standards might be met with Chelsom lighting.

TRADE ASSOCIATION MEMBERSHIPS



CHELSON HAVE TECHNICAL SPECIALISTS AVAILABLE TO ANSWER ANY OF YOUR QUERIES. PLEASE CONTACT THE TECHNICAL DEPARTMENT FOR INFORMATION.

**E-mail: sales@chelsom.co.uk
Tel: +44 (0)1253 831400**

CABLE AND PLUGS

Cable colour will be selected to complement the finish of the luminaire. Portable luminaires will normally have 2 metres cable length from the base to a 13 amp UK plug (fused 3 amp). 5 amp plugs and many international plugs are available.

PENDANT LUMINAIRES

Pendants are normally supplied with 2000mm of suspension chain or cable and all have ceiling plates. Refer to the website for full technical specifications and installation instructions. To facilitate maintenance of larger pendants in high-ceilinged rooms, we can advise upon and arrange installation of manual or power winches.

DIMENSIONS AND WEIGHTS

Dimensions are usually rounded to the nearest 10mm, 5mm for smaller products. Minimum heights shown for pendants include one link of chain, where applicable, and the ceiling plate. Maximum heights include the above plus the normal amount of chain supplied (extra lengths available on request). Weights for pendants are shown and include glass where illustrated. Portable luminaire base only heights are measured including lampholder cover and heights with shade relate to the shade illustrated. Projection is the maximum distance any part of a wall light extends from the wall including shade if shown.

CONVERSION Chart (millimetres to inches)

mm	inches	mm	inches	mm	inches	mm	inches
10	0.4	510	20.1	1010	39.8	1510	59.4
20	0.8	520	20.5	1020	40.2	1520	59.8
30	1.2	530	20.9	1030	40.6	1530	60.2
40	1.6	540	21.3	1040	40.9	1540	60.6
50	2.0	550	21.7	1050	41.3	1550	61.0
60	2.4	560	22.0	1060	41.7	1560	61.4
70	2.8	570	22.4	1070	42.1	1570	61.8
80	3.1	580	22.8	1080	42.5	1580	62.2
90	3.5	590	23.2	1090	42.9	1590	62.6
100	3.9	600	23.6	1100	43.3	1600	63.0
110	4.3	610	24.0	1110	43.7	1610	63.4
120	4.7	620	24.4	1120	44.1	1620	63.8
130	5.1	630	24.8	1130	44.5	1630	64.2
140	5.5	640	25.2	1140	44.9	1640	64.6
150	5.9	650	25.6	1150	45.3	1650	65.0
160	6.3	660	26.0	1160	45.7	1660	65.4
170	6.7	670	26.4	1170	46.1	1670	65.7
180	7.1	680	26.8	1180	46.5	1680	66.1
190	7.5	690	27.2	1190	46.9	1690	66.5
200	7.9	700	27.6	1200	47.2	1700	66.9
210	8.3	710	28.0	1210	47.6	1710	67.3
220	8.7	720	28.3	1220	48.0	1720	67.7
230	9.1	730	28.7	1230	48.4	1730	68.1
240	9.4	740	29.1	1240	48.8	1740	68.5
250	9.8	750	29.5	1250	49.2	1750	68.9
260	10.2	760	29.9	1260	49.6	1760	69.3
270	10.6	770	30.3	1270	50.0	1770	69.7
280	11.0	780	30.7	1280	50.4	1780	70.1
290	11.4	790	31.1	1290	50.8	1790	70.5
300	11.8	800	31.5	1300	51.2	1800	70.9
310	12.2	810	31.9	1310	51.6	1810	71.3
320	12.6	820	32.3	1320	52.0	1820	71.7
330	13.0	830	32.7	1330	52.4	1830	72.0
340	13.4	840	33.1	1340	52.8	1840	72.4
350	13.8	850	33.5	1350	53.1	1850	72.8
360	14.2	860	33.9	1360	53.5	1860	73.2
370	14.6	870	34.3	1370	53.9	1870	73.6
380	15.0	880	34.6	1380	54.3	1880	74.0
390	15.4	890	35.0	1390	54.7	1890	74.4
400	15.7	900	35.4	1400	55.1	1900	74.8
410	16.1	910	35.8	1410	55.5	1910	75.2
420	16.5	920	36.2	1420	55.9	1920	75.6
430	16.9	930	36.6	1430	56.3	1930	76.0
440	17.3	940	37.0	1440	56.7	1940	76.4
450	17.7	950	37.4	1450	57.1	1950	76.8
460	18.1	960	37.8	1460	57.5	1960	77.2
470	18.5	970	38.2	1470	57.9	1970	77.6
480	18.9	980	38.6	1480	58.3	1980	78.0
490	19.3	990	39.0	1490	58.7	1990	78.3
500	19.7	1000	39.4	1500	59.1	2000	78.7

Copyright 2020 Chelsom Ltd

To convert millimetres to inches: millimetres x 0.03937
To convert inches to millimetres: inches x 25.4

INDEX

Model No.	Page	Model No.	Page	Model No.	Page	Model No.	Page	Model No.	Page
AC/79/12	308	BH/40/P/*	217/294	BW/230/*	162	CI/38/SF/*	268	DI/35/F	60/260
AC/79/3	308	BH/40/W1/*	217/294	BW/73/*	165	CK/6/FS	57	DI/35/P	60/260
AC/79/9	308	BI/22/DL/*	152	BW/82/*	164	CK/6/TL	57	DI/36/P	61/260
AC/79/W2	308	BM/56/P	214/293	BX/44/FS	92	CK/6/W1	57	DI/36/W1	61
AD/35/FF	278	BM/56/W2	214/293	BX/44/P	92	CN/21/FS	107	DL/12/*	150-151
AD/35/FF2	279	BO/22/FS/*	78	BX/44/TL	93	CN/21/TL	107	DL/16/BB/EBR	147
AD/35/WW	278	BO/22/TL/*	79	BX/44/W1	92	CN/21/W1	107	DL/4/*	148
AI/56/1200/P	289	BO/22/W1/*	78	CA/12/FS2	56	CO/9/BB/EBR	186	DL/41/*	149
AI/56/300/W2	288	BR/5	312	CA/12/TL2	56	CP/24/4/*	296	DM/87/6	292
AI/56/450/F	288	BT/8/FS	52	CA/12/W2	56	CP/24/FF/*	296	DN/125/C	298
AI/56/600/P	289	BT/8/TL	52	CB/9/WW/*	221	CP/24/P/*	296	DN/20/*	298
AL/25/FS/*	109	BT/8/W1	52	CC/110/FS/BB/EBR	83	CP/24/TL/*	74	DN/35/BL	298
AL/52/DL/*	108	BU/40/FF/L	299	CC/110/TL/BB/EBR	83	CP/24/W1/*	74	DR/8/W1/BB	229
AL/52/W1/*	109	BU/40/FF/S	299	CC/110/W1/BB/EBR	82	CR/7/DL/BL/C	154	DT/14/W1	211
AO/007/P	216/295	BV/6/3	274-275	CD/22/TL/*	173	CR/7/FS/BL/C	154	DT/14/W2/*	166/211
AO/007/W1	216/295	BV/6/6	274	CE/6/BRB	258	CV/16/FS/C	94	DU/6/W2/*	167/210
AS/36/TL/*	36	BV/6/6+3	275	CE/9/BRB	258-259	CV/16/TL/C	95	DW/6/FS	110
AS/36/W1/*	37	BV/6/W1	274	CF/8/P	261	CV/16/W1/C	94	DW/6/TL	110
AT/85/P/*	281	BW/106	163	CH/9/FS/*	85-86	CV/17/TL/C	94	DW/6/W1	110
AU/22/P	257	BW/110/LED	162	CH/9/TL/*	85-86/189	CX/14/FS/*	102	DW/6/W1/LED	111
AU/22/WW	257	BW/112/LED	167	CH/9/W1/*	84-86	CX/14/TL/*	103	DY/100/FS/*	43
AV/60/FS/*	114-115	BW/116/LED	162	CH/9/W1/LED/*	84-86	CX/14/W1/*	102	DY/100/TL/*	42
AV/60/TL/*	114-115	BW/158	163	CI/35/F/*	269	CZ/30/FS	48	DY/100/W1/*	42
AV/60/W1/*	114-115	BW/21/*	164	CI/35/SF/*	268	CZ/30/P	48	ET/7000/3P	245
BA/5/W1/*	228	BW/22	163	CI/35/W2/*	269	CZ/30/TL	49	ET/7000/800F	244
BC/10/TL	155	BW/220/*	162	CI/36/W2/*	269	CZ/30/W1	48	EX/5/DL/*	97

* See suffix options on the relevant page.

Model No.	Page	Model No.	Page	Model No.	Page	Model No.	Page	Model No.	Page
EX/5/FS1/*	96	GS/200/*	270-271	IC/24/6+6	251	LED/5/2/W1L/*	134	MA/9/W1	212
EX/5/FS2/*	96	GS/40/*	276-277	IC/24/P	250	LED/5/2/W1R/*	134	MD/8/W1	230
EX/5/TL/*	97	GS/66/SM	178	IC/24/W2	250	LED/500/*	142	MD/8/W2	230
FA/30	191	GS/TQ/170	75	IN/12/DL/BNC	119	LED/7/*	136-137	MF/22/W2/*	207
FA/80	191	GS/TQ/250	75/297	IN/12/FS/BNC	118	LED/7/DL/*	153	MY/122/L/*	315
FJ/41/16+8	287	GS/TQ/350	75/297	IN/12/TL/BNC	119	LED/750/*	142	MY/122/M/*	314
FJ/300/P	311	GX/102/1000/30+24+18	285	IN/12/W1/BNC	118	LED/7A/*	136-137	MY/122/S/*	314
FJ/300/W1	311	GX/102/600/18	284	IN/12/W1/LED/BNC	118	LED/8/*	140	MY/122/W2/*	314
FJ/450/P	311	HA/100/10	254	KT/24/200	232	LED/800/*	142	NM/6/250x250/BRG	204
FJ/600/P	310	HA/100/4	255	LED/10/*	138	LG/1/*	174	NM/6/300/BRG	204
FP/741/OPAL	297	HA/100/8	255	LED/10/W1/*	139	LG/2/*	175	NM/6/300x100/BRG	205
FP/742/OPAL	297	HA/100/W1	254	LED/10/W2/*	139	LG/3/*	176	NM/6/300x100/C	167
GA/28	183	HA/100/W1A	255	LED/100/*	142	LG/3P/*	300	NM/6/300x100/LED/BRG	205
GA/29	183	HA/100/W2	254	LED/10A/*	138	LG/4/*	177	NM/6/500/BRG	204
GA/33/SM	179	HD/25/3	262	LED/10A/USB/*	138	LG/5P/*	301	NM/6/600x150/BRG	205
GA/44/SM	179	HD/25/5	263	LED/11/*	126-128	LK/10/W1	218	NM/6/600x150/C	166
GA/59	182	HD/25/W1	262	LED/14/*	141	LN/34/FS/*	63-64	OC/88/W1	208
GC/400/P/L	247	HD/25/W1/RN	227	LED/300/*	142	LN/34/TL/*	63-65	OD/30/W1/BRB	213
GC/400/P/S	246	HQ/15/P	46	LED/350/*	142	LN/34/W1/*	63-64	OR/41/10	267
GC/400/WW	246	HQ/15/TL	47	LED/418/*	143	LN/34/W2/*	63-64	OR/41/6	266
GE/0470/CL	200	HQ/15/W1	46	LED/418/SW/*	143	LN/34/WW/*	63-64	OR/41/P	266
GE/1280/GL	200	HQ/16/W1	46	LED/5/1/*	130-133	LN/34/WW/C	163	OR/41/W1	266
GE/20203/GL	201	HY/77/FS/*	40	LED/5/1/USB/*	132	LX/6/FS	44	OS/9/TL	172
GE/742/*	198-199	HY/77/TL/*	41	LED/5/2/*	131-133	LX/6/P	44	OX/42/3/BRB	270
GM/66/W1/*	165/206	HY/77/W1/*	40	LED/5/2/KNURL/*	129	LX/6/TL	45	OX/42/6/BRG	271
GN/950/W2/BZ	235	IC/24/12+6	252	LED/5/2/W1/USB/*	135	LX/6/WW	44	OX/42/P/BRB	271

* See suffix options on the relevant page.

INDEX

Model No.	Page	Model No.	Page	Model No.	Page	Model No.	Page	Model No.	Page
OX/42/W1/BRB	270	PM/28/800/P	307	Q9/7/*	186	QDW/10/*	110	QPP/W1/*	53
OX/42/W2/BRB	271	PM/28/W2	306	QBN/600/*	312	QDW/5/*	110-111	QRTS/*	316
PB/50/BN	220	PP/12/FS	53	QBR/*	317	QDY/FS/*	43	QSD/10/*	56 /106
PB/70/W1/BN	220	PP/12/TL	53	QBV/6/*	274	QDY/TL/*	42	QSD/14/*	106
PE/60/BL/COP	298	PP/12/W1	53	QBV/700/*	275	QDY/W1/*	42	QSG/W1/*	230
PH/05/FS	51	PR/24/TL	184	QBW/5/BW	167	QEL/*	317	QSH/6/*	76
PH/05/TL	51	PS/12/TL/*	170	QBW/6/WC	163	QEL/12H/*	302	QSI/10/*	58-59
PH/05/W1	51	PT/4/FS/*	104	QBX/FS/*	92	QEL/20H/*	302	QSI/7/*	58-59
PI/38/FS	81	PT/4/TL/*	105	QBX/P/*	92	QEX/DL/*	97	QST/*	316
PI/38/TL	80-81	PT/4/W1/*	104	QBX/TL/*	93	QEX/FS1/*	96	QSX/TL/*	55
PI/38/W1	81	PX/14/5P	234/253	QBX/W1/*	92	QEX/FS2/*	96	QSX/W1/*	55
PJ/9/DL/C	117	PX/14/P	253	QCHB/14/*	85-86/189	QEX/TL/*	97	QTR/FS/*	100-101
PJ/9/FS/C	116	PX/14/W1	234/253	QCHB/14/*	84/86/189	QFD/*	316	QTR/TL/*	100-101
PJ/9/RL/C	116	PZ/4/FS	112	QCHB/18/*	85	QKE/7/SC/*	302	QTR/W1/*	100-101
PJ/9/TL/C	117	PZ/4/TL	112	QCK/12/*	57	QLI0/*	139	QTR/W1/SHORT/*	100-101
PJ/9/TL/LED/C	117	PZ/4/W1	112	QCK/6/*	57	QMD/2/*	230	QTW/5/*	231
PJ/9/W1/C	116	Q/12/*	150	QCN/12/*	107	QMD/CYL/*	230	QTY/P/*	72
PJ/9/W1/IP44	167	Q110/FS/*	83	QCN/6/*	107	QMD/W1/*	230	QWE/200/*	312
PK/16/FS/BB	87	Q110/TL/*	83	QCO/6/SC/*	303/315	QOB/*	317	QWE/700/*	312
PK/16/TL/BB	87	Q110/W1/*	82	QCX/10/*	103	QPH/11/*	51	RA/4/DL	68
PK/16/W1/BB	87	Q22/FS/*	78	QCX/18/*	102	QPH/7/*	51	RA/4/P	68/264
PL/6/300/*	237	Q22/TL/*	79	QCX/8/*	102	QPK/10/*	87	RA/4/W1	68/264
PL/6/550/*	237	Q22/W1/*	78	QCY/*	316	QPK/12/*	87	RA/4/W2	69/264
PL/8/300/*	236	Q26B/*	226	QDL/7/*	147	QPK/16/*	87	RA/5/W1	68/264
PL/8/550/*	236	Q5/*	134	QDR/8/*	229	QPP/FS/*	53	RG/3/6/*	256
PM/28/650/P	307	Q5USB/*	135	QDR/M/BB	229	QPP/TL/*	53	RG/3/W1/*	256

* See suffix options on the relevant page.

Model No.	Page	Model No.	Page	Model No.	Page	Model No.	Page	Model No.	Page
RI/23/FS/BRB	54	SA/29/600/P	291	SN/28/300	280	TM/18/TL	185	WE/10/700	312
RI/23/TL/BRB	54	SA/30/W2	291	SN/28/600	280	TM/22/TL	185	WI/40/5	276
RI/23/W1/BRB	54	SC/26B/BL	226	SS/21/GO	305	TO/10/FS/*	98-99	WI/40/8	277
RK/10/FS	70	SD/20/FS	106	SS/67/W1	302	TO/10/TL/*	98-99	WI/40/W1	276-277
RK/10/TL	70	SD/20/TL	106	SS/80/4P/GO	304	TO/10/W1/*	98-99	WK/70/FS	113
RK/10/W1	70	SD/20/W1	106	SS/80/W1/GO	233/304	TQ/100/250	75/297	WK/70/TL	113
RK/11/TL	71	SE/14/DL/BL/BRB	62	SS/81/W2/GO	233/304	TQ/100/350	75/297	WK/70/W1	113
RM/9/FS	66	SE/14/FS/BL/BRB	62	SS/90/6+3	303	TQ/100/TL	75	WT/23/W1/BB/EBR	230
RM/9/P	66	SE/14/W1/BL/BRB	62	SS/90/8+4	303	TQ/100/W1	75		
RM/9/TL	67	SF/29/8	214/265	SS/90/FS	190	TR/4/FS/*	100-101		
RM/9/W1	66	SF/29/W1	215/265	SS/90/TL	190	TR/4/TL/*	100-101		
RN/01	227	SG/24/TL/BRB	188	SS/90/W2	302	TR/4/W1/*	100-101		
RN/03	227	SG/25/W1/BB	230	SS/93/W1	302	TR/4/W1/LED/*	100-101		
RO/42/1P	286	SH/60/TL2/BB/EBR	76-77	SW/39/FS/*	90-91	TW/58/W2/GO	231		
RO/42/28+18	286	SH/60/W1/BB/EBR	76	SW/39/TL/*	90-91	TY/10/P	72		
RR/30/W1/BRB	224	SH/60/W2/BB/EBR	76	SW/39/W1/*	90-91	TY/10/TL	72-73		
RR/30/W1L/BRB	224	SI/23/FS/*	58-59	SW/40/FS/*	89	TY/10/W1	72		
RS/10/3TIER	282	SI/23/TL/*	58-59	SW/40/TL/*	89	UR/6/FS/*	120/122		
RS/10/4TIER	283	SI/23/W1/*	58-59	SW/40/TL/EBR/STONE	146	UR/6/TL/*	121-122		
RS/10/855	282	SK/24/*	180-181	SW/40/W1/*	88	UR/6/W1/*	120/122		
RY/68/6	272	SK/26/*	180-181	SX/48/TL	55	UR/6/W1/LED/*	120/122		
RY/68/8	273	SK/27/EBR	181	SX/48/W1	55	VE/2/3P	219/249		
RY/68/W1	272	SK/28/BN	180	SY/45/TL/BL/GB	50	VE/2/P	219/248		
RY/68/W2	272	SL/11/W1	222	SY/45/W1/BL/GB	50	VE/2/W1	219/248		
SA/28/900/F	290	SL/12/W1	223	SZ/00/W1	171/209	VG/37/TL/AB/*	187		
SA/28/900/P	290	SN/28/250	280	SZ/100/TL	171/209	WE/10/200	312		

* See suffix options on the relevant page.

