

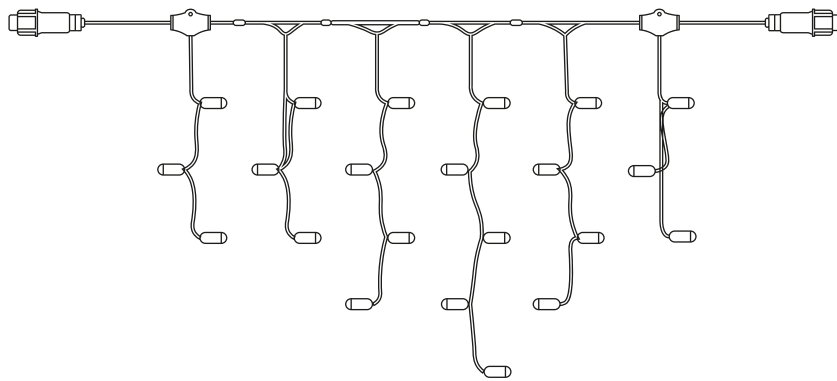

Read these instructions & save for future use

PS230 | icicle light | 2x0,4m | white wire | 6500K CW



Article number **007-140**

Brand **Tronix Lighting**

Type **Pro system modular | Icicle lights**

Contents of this product **2x0,4m 5,5W icicle light 6500K**

Technical datasheet **Digitally available
on our webshop**



*View instructions and
technical data also on
our website*

TRONIX



Before first use

Before getting started with this product, it is advisable to check the order completeness and any damage. If this is the case, please contact Tronix Lighting.

Description

PS230 is a distinctive system within the world of professional LED lighting. The system contains countless possibilities when it comes to creating your own lighting design.

Whether decorating a house, restaurant or store, the system is called a solution for everything!

Features

- IP65 for outdoor use;
- High-quality composition of materials for long life;
- Up to a maximum of 50 meters in one coupling.

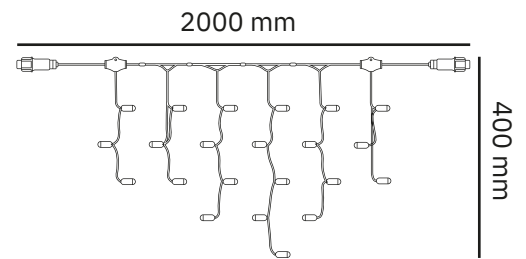

Installation

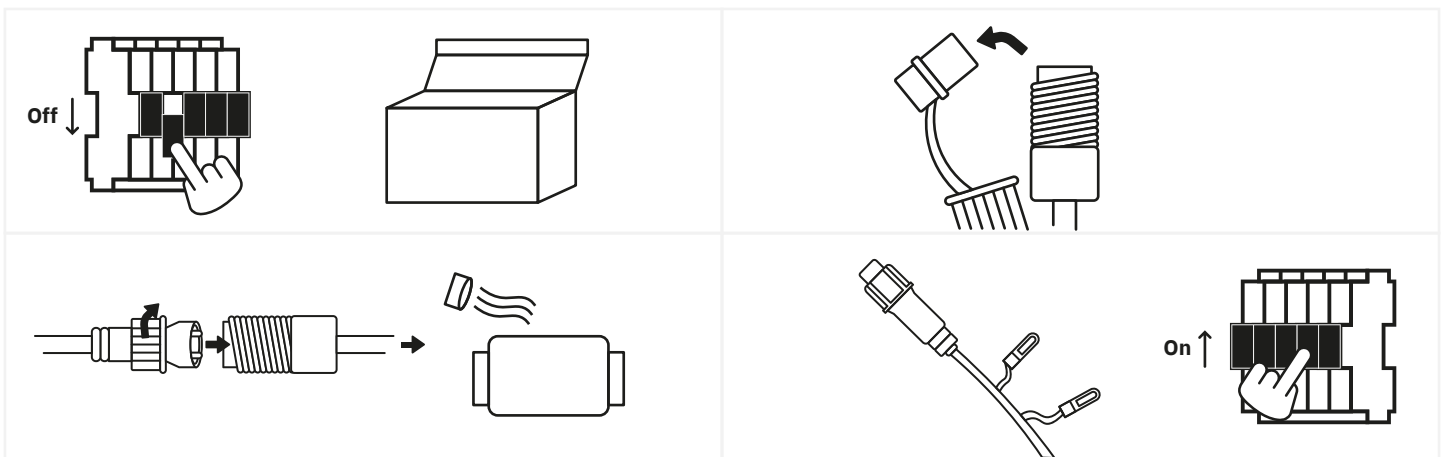

1. Turn off the power and remove the product and associated parts from the packaging;
2. Unscrew one or both caps and connect the female connector to the corresponding PS230 plug;
3. Check that the connection is okay and then screw cap back over plug. This ensures a water-resistant seal. When looping through, please connect the next set to the end of the current set. For extra protection it is recommended to put a jacket around the coupler. Then secure it by means of a heatgun;
4. Check the complete installation. If everything is in order, you can reactivate the power.



Safety

Safety is a top priority at Tronix Lighting. Therefore, we heartily recommend that you follow the following steps closely:

- Keep this manual carefully for future reference;
- Choose a qualified electrician while installing, maintaining or inspecting this product;
- Never look directly into a light source to avoid possible eye damage;
- Ensure that the respective power group is always on non-active when the product is connected;
- Use only recommended combinations (LED drivers, controllers or dimmers) to avoid injury or damage to the product;
- The light sources of this product is not replaceable. Because of this, you must replace the entire fixture towards the end of its lifespan and it is not recommended to open it.

Technical problems and repair

Should a product not work properly after installation, or if the product exhibits problems over time, it is advisable to check the following elements:

- Check the wiring and installation of your product;
- Check for the presence of interfering elements such as dust, water or other electronics;
- If possible, try disconnecting the product and testing it in another location to rule out a problem at the location;
- Should you be dealing with a WIFI-based product, check and reset your router's settings.

Should the product still not work after testing, it is recommended to send it in for inspection and/or repair. To do so, please contact Tronix Lighting using nearby details and proof of purchase (packing slip).



CARE



SHARE



CONNECT

Supplier:

Tronix Lighting B.V

Vluchtoord 41
5406 XP Uden, Netherlands

+31 (0)413 330 380
sales@tronixlighting.com

Terms and symbols (as relevant to product)



The **CE mark** indicates that this product complies with EU regulations on safety, health and environmental protection;



The **WEEE symbol** stands for "Waste Electrical and Electronic Equipment Regulation," a directive on the collection, recycling and recovery of electronic waste;



The **Class II symbol** indicates that this product is double insulated;

- This product has an **IP65 rating**. This means the housing is touch-safe, fully protected from dust and spray-proof (12.5 L/min) regardless of angle.