

LESELI CCT

incassato / downlight / einbauleuchten
/ empotrado / vgradna svetilka

art.	W	lm	K	PF	▲	Ø	L
DT40L1CCT	12	1200*	3000-4000-6000	0,5	110°	140	54
DT80L1CCT	22	2200*	3000-4000-6000	0,5	110°	216	58
DT80L1CCTHP	30	3000*	3000-4000-6000	0,9	110°	216	58

* I dati di lumen e potenza indicati si riferiscono alla temperatura di colore 4000K

* The lumen and power data indicated refer to the 4000K colour temperature

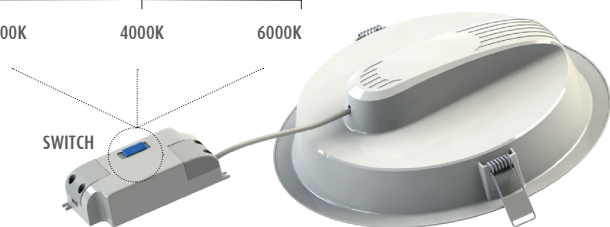
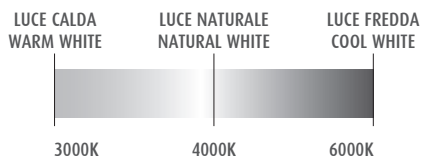

IP20 VI
IP43VO

12W = Ø 125 mm ± 2 mm
22W = Ø 200 mm ± 2 mm
30W = Ø 200 mm ± 2 mm

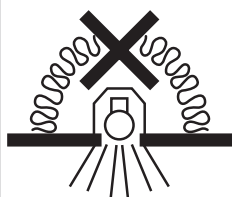
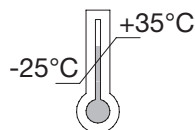

Non adatto ad essere coperto con materiale termicamente isolante. In caso di dubbi sulla simbologia riferirsi al catalogo o al sito web.

Not suitable for covering with thermally insulated material.
In case of doubt about the symbols, please refer to catalogue or website.

Svetilka ni primerna za montažo kjer je neposreden stik z izolacijo stropa.
Potrebno zagotoviti primerno prezračevanje nad svetilko.

I

- ⇒ Cavi liberi. Necessita di installazione da parte di personale qualificato.
- ⇒ Necessita di morsettiera conforme alla norma EN60998-2-1 o EN60998-2-2, con le seguenti caratteristiche: terminale a 3 vie (L+N+PE); 220-240V; □min 1,0mm²; per installazione indipendente.

GB

- ⇒ Screwless terminal, terminal block not included. Installation may require advice from a qualified person.
- ⇒ To be provided with screw terminal block conform to EN60998-2-1 or EN60998-2-2, with the following characteristics: 3 ways terminal (L+N+PE); 220-240V; □min.1,0mm²; for independent installation.

E

- ⇒ Cables libres. Requiere la instalación por personal cualificado.
- ⇒ Necesita de un terminal conforme con la norma EN60998-2-1 o EN60998-2-2, con las siguientes características: terminal de 3-vías (L+N+PE); 220-240V y □min. 1.0 mm², para su instalación independiente.

D

- ⇒ Elektrischer Anschluss über freie Kabelenden, Klemme Bauseits. Montage darf nur durch Fachkräfte durchgeführt werden.
- ⇒ Verwendete Schraubklammern müssen der Norm EN60998-2-1 oder EN60998-2-2 entsprechen und folgende Merkmale aufweisen: 3 Leiter Trennung (L+N+PE); 220-240 Volt; Min. □1,0mm²; für ortsunabhängige Montage verwendbar.

SLO

- ⇒ Odprti napajalni kabel. Zahtevno montažo s strani pooblaščenega osebe.
- ⇒ Za priklop uporabiti primerno sponko in skladno s predpisi EN60998-2 ali EN60998-2-2. Dodatne zahtevane karakteristike sponke: 2 polni priključek (L+N+PE); 220-240V presešek; □1,0 mm² za samostojni priklop.

I - L'APPARECCHIO DEVE ESSERE INSTALLATO DA PERSONALE QUALIFICATO. L'AZIENDA DECLINA OGNI RESPONSABILITA' QUALORA L'INSTALLAZIONE NON AVVENGA SECONDO LE NORME VIGENTI. METODO DI ATTACCO DEL CAVO TALE PER CUI LA SUA SOSTITUZIONE NON PUO' ESSERE EFFETTUATA SENZA ROMPERE O DISTRUGGERE L'APPARECCHIO. LASCIARE UNA COPIA DI QUESTE ISTRUZIONI AL RESPONSABILE DELLA MANUTENZIONE. CONSERVARE L'ETICHETTA DELL' IMBALLO ORIGINALE PER EVENTUALI RECLAMI FUTURI.

GB - THIS FIXTURE MUST BE INSTALLED BY A QUALIFICATED ELECTRICIAN. DURALAMP IS NOT RESPONSIBLE IF ITS FIXTURES ARE NOT INSTALLED ACCORDING TO LOCAL SAFETY STANDARDS. METHOD OF ATTACHMENT OF THE CABLE OR CORD SUCH THAT IT CANNOT BE REPLACED WITHOUT BREAKING OR DESTROYING THE LUMINAIRE. PLEASE LEAVE A COPY OF THESE INSTRUCTIONS TO THE PERSON RESPONSABLE FOR THE MAINTENANCE OF THE INSTALLATION. KEEP THE LABEL OF THE ORIGINAL PACKING FOR THE EVENTUAL FUTURE CLAIMS.

F - L'APPAREIL DOIT ETRE INSTALLE PAR ELECTRICIENS QUALIFIES. DURALAMP NE PEUT PAS ETRE RESPONSABLE POUR TOUTES INSTALLATIONS QUI NE RESPECTENT PAS LES NORMES DE SECURITE EN VIGUEUR. METHODE D'ATTACHE DU CABLE TELLE QUE SA SUBSTITUTION NE PEUT SE FAIRE SANS DETRUIRE L'APPAREIL. LAISSER UNE COPIE DE CES INSTRUCTIONS AU RESPONSABLE DE L'ENTRETIEN DU SYSTEME. GARDER L'ETIQUETTE DE L'EMBALLAGE ORIGINAL POUR EVENTUELLES RECLAMATIONS FUTURES.

D - DAS GERÄT MUSS VON ELEKTROINSTALLATEUREN MONTIERT WERDEN. DURALAMP IST NICHT VERANTWORTLICH WENN DIE MONTAGE NICHT GEMÄß DER SICHERHEITSVORSCHRIFTEN STATTFINDET. TED KABELANSCHLUSS SO AUSFÜHREN, DASS DAS KABEL NICHT OHNE DIE LEUCHTE ZU ZERSTÖREN GEWECHSELT WERDEN KANN. DIESES HINWEISBLATT MUß VOM INSTANDHALTUNGSLEITER AUFBEWAHRT WERDEN. BEI REKLAMATIONEN BITTE DEN ARTIKELAUFKLEBER AUS DER LEUCHTENVERPACKUNG BEIFÜGEN.

S - ARMATUREN MÄSTE INSTALLERAS AV GODKÄND ELEKTRIKER. DURALAMP KAN INTE PÅTÄGES NÅGOT ANSVAR FÖR ATT PRODUKTEN INTE INSTALLERATS ENLIGT GÄLLANDE BESTÄMMELSER VÄNLIGEN ÖVERLÄMNA DESSA INSTRUKTIONER TILL ANSVARIG FÖR INSTALLATIONEN. BEHÅLL ORIGINAL ETIKETTEN PÅ FÖRPACKNINGEN FÖR EVENTUELLA REKLAMATIONER.

NL - HET ARMATUUR MOET GEINSTALLEERD WORDEN DOOR EEN ERKEND ELECTROTECHNISCH INSTALLATEUR. DURALAMP IS NIET AANSPRAKELIJK INDIEN HAAR PRODUCTEN NIET VOLGENS DE LANDELIJKE VEILIGHEIDSNORMEN WORDEN GEINSTALLEERD. METHODE VAN AANBRENGEN VAN DE DRAAD OP ZO'N MANIER DAT VERVANGING NIET MOGELIJK IS ZONDER HET APPARAAT TE BESCHADIGEN OF KAPOT TE MAKEN. WILT U ZO VRIENDELIJK ZIJN EEN COPIE VAN DEZE INSTRUCTIES ACHTER TE LATEN BIJ DEGEN DIE VERANTWOORDELIJK IS VOOR HET ONDERHOUD. BEWAAR HET LABELTJE VAN DE ORIGINALE VERPAKKING.

E EL APARATO DEBE SER INSTALADO POR ELECTRICISTAS CUALIFICADOS. DURALAMP NO SE RESPONSABILIZARA DE TODAS LAS INSTALACIONES QUE NO RESPETEN LAS NORMAS DA SEGURIDAD EN VIGOR. MÉTODO DE FIJACIÓN DEL CABLE CUYA SUSTITUCIÓN NO PUEDE REALIZARSE SIN ROMPER O DESTRUIR EL DISPOSITIVO. ENTREGAR UNA COPIA DE ESTAS INSTRUCCIONES AL RESPONSABLE DE LA INSTALACION. CONSERVAR LA ETIQUETA DEL EMBALAJE ORIGINAL PARA POSIBLES RECLAMACIONES.

SLO - PRIKLOP SVETILKE MORA IZVEST POOBLAŠČENA OSEBA. V KOLIKOR JE MONTAŽA IZVEDENA S STRANI NEPOOBLAŠČENE OSEBE ODGOVORNOST UVOZNIKA IN PROIZVAJALCA POSTANE NIČNA. POSEGV ARTIKEL ALI ZAMENJAJVA NAPAVALNEGA KABLA NI PREDVIDENA. VEDNO JE POTREBNO SHRANITI KOPIJO NAVODIL ZA MONTAŽO ZA KASNEJŠI VPOGLED S STRANI VZDRŽEVALCEV.

RG1

RG1 secondo norma IEC/TR 62778:2014 / RG1 in accordance with IEC/TR 62778:2014
RG1 selon la norme IEC/TR 62778:2014 / RG1 nach der norm IEC/TR 62778:2014
RG1 enlight IEC/TR 62778:2014 / RG1 volgens IEC/TR 62778:2014
RG1 de acordo com norma IEC/TR 62778:2014 / RG1 po predpisu IEC/TR 62778:2014

**ISTRUZIONI DI MONTAGGIO:
INSTALLATION/MOUNTING:**

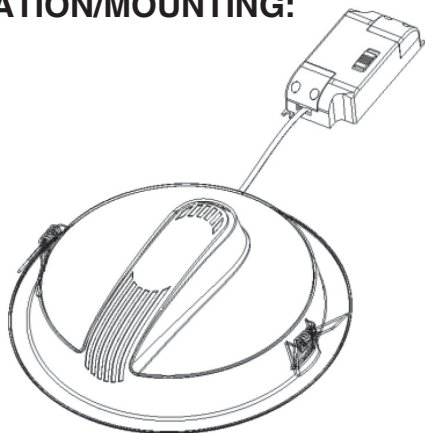
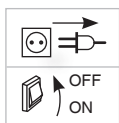

1

Assicurati di spegnere l'alimentazione principale
Make sure to turn off the main power

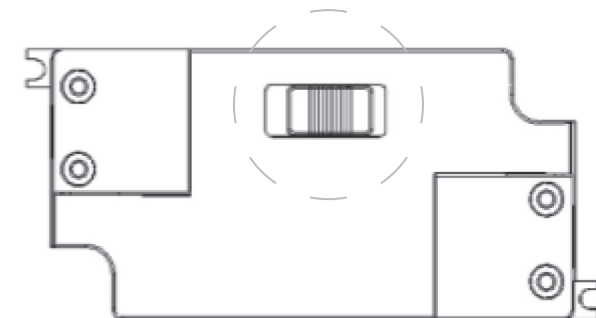

2

Posizionare lo switch sul colore desiderato
Adjust the dip-switch to proper position

3

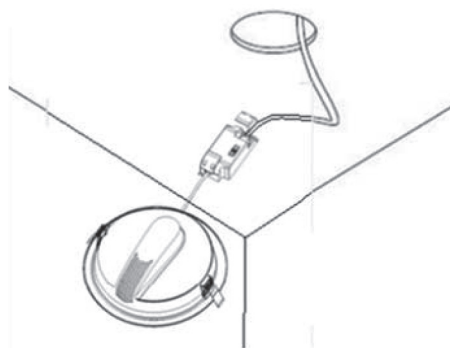
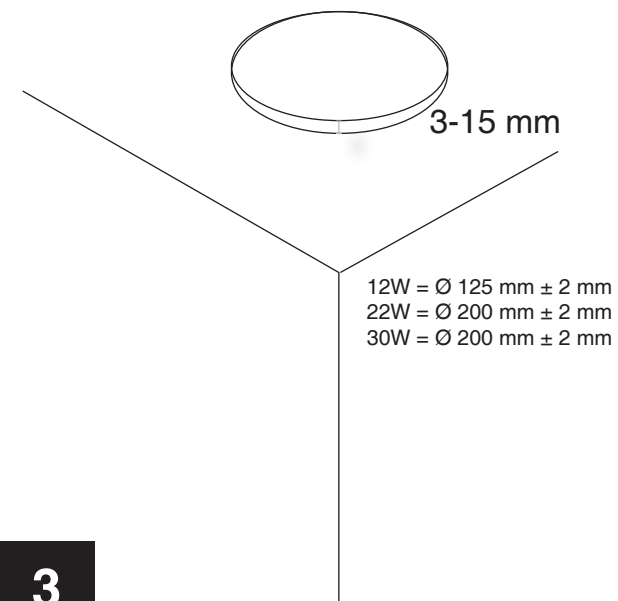

4

Collegare il cavo di alimentazione all'unità
Connect the power cable to the drive



5

Spingere la molla verso l'alto, sollevare sufficientemente il prodotto in modo che la molla possa essere inserita nel soffitto
Push the spring upward, sufficiently lift the product so that the spring can be inserted into the ceiling

6

Riaccendere l'interruttore per verificare che il prodotto funzioni correttamente
Turn the power switch back on to verify that the product is working properly

