



FEATURES

TINY POINT OF LED LIGHT PROJECTS A SPARKLING GLOW INTO SCULPTURED CRACKLE GLASS PEAR. LARGE CUSTOM CASCADES OR SPIRALS ARE AVAILABLE TO SPECIAL ORDER.

MATERIAL

GLASS AND STEEL

FINISH

BRUSHED BRASS WITH CLEAR CRACKLE GLASS

CERTIFICATIONS

CE UK CA UL IP20

DIMENSIONS



FULL TECHNICAL SPECIFICATION

MATERIAL	GLASS AND STEEL	DIMMABLE AS STANDARD?	BY REQUEST ONLY
FINISH	BRUSHED BRASS WITH CLEAR CRACKLE GLASS	INSULATION RATING	CLASS I
LAMPHOLDER TYPE	INTEGRAL LED	IP RATING	IP20
INTEGRAL LIGHT SOURCE	LED 1W 2700K	WIDTH	100
COLOUR TEMPERATURE	2700K	MINIMUM DROP	250MM
CE	YES	MAXIMUM DROP	3000MM
UKCA	YES	CEILING PLATE DIMENSIONS	100MM DIAMETER
UL	YES	NET PRODUCT WEIGHT	1KG
DRIVER LOCATION	INTEGRAL	OVERALL WIDTH AS SHOWN	100MM
SUSPENSION TYPE	CLEAR PLASTIC CABLE		

FOR MORE INFORMATION ABOUT THIS PRODUCT:

Email: sales@chelsom.co.uk | Call: +44 (0)1253 831400

Chelsom Limited, Heritage House, Clifton Road, Blackpool, Lancashire FY4 4QA, United Kingdom

www.chelsom.co.uk

— CHELSOM —

INSTALLATION INSTRUCTION

1. The installation of all electrical products should be undertaken with utmost care and a qualified electrician should carry out the work to ensure compliance with any local wiring regulations.
2. Always ensure that the mains electrical supply is disconnected before removing an existing luminaire and installing a new one.
3. Check the routing of electrical supply cable to avoid cutting it or damaging it during installation.
4. Make all electrical connections in accordance with the instructions attached to the luminaire itself following relevant local codes and regulations at all times. Ensure all connections are not loose with wire parts properly covered.
5. Ensure the light source is compatible with local voltage and follow any maximum wattage instructions shown on the product itself.
6. If you have any questions regarding the installation of this luminaire, please contact Chelsom Head Office for assistance.

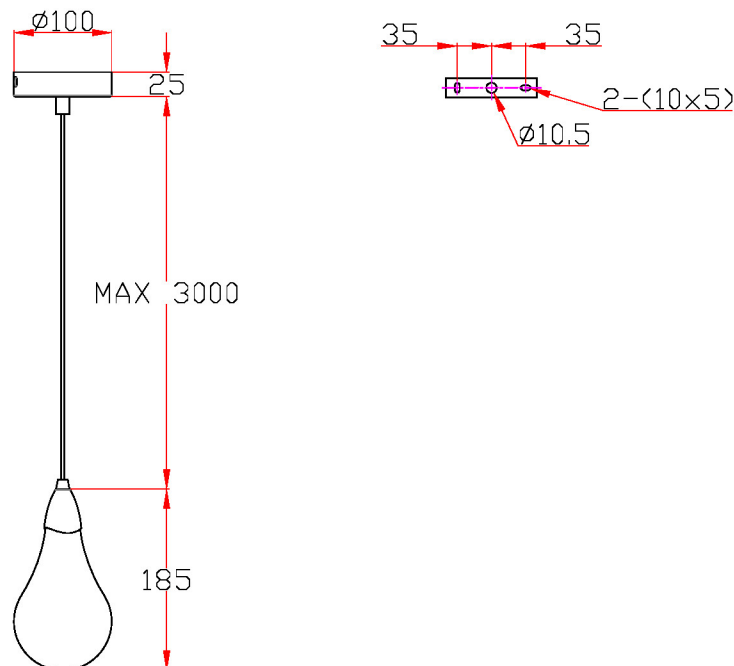

— CHELSOM —

FOLLOW THE NUMBERED ASSEMBLY SEQUENCE

