

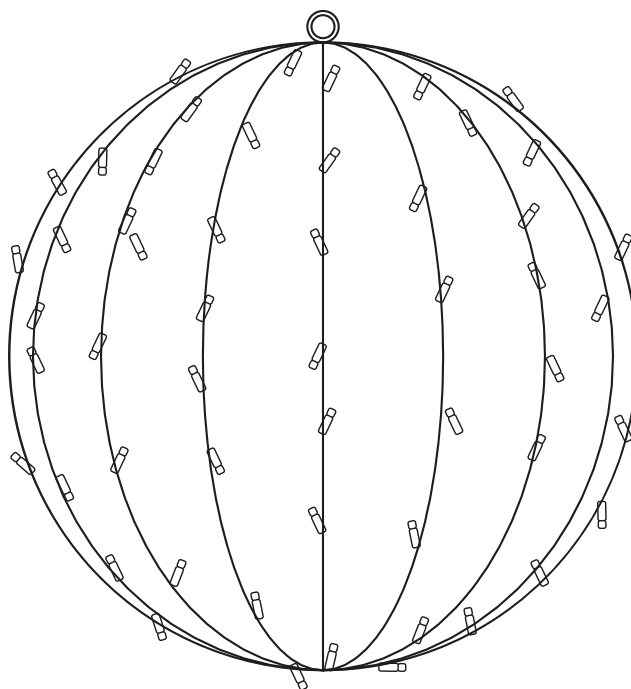

Read these instructions & save for future use

## 3D ball | 50cm | black cable | 2400K WW+ flash 2400K WW



Article number **571-017**

Brand **Tronix Lighting**

Type **Motifs**

Contents of this product **1x 10W 3D ball 2400K**

Technical datasheet **Digitally available  
on our webshop**



*View instructions and  
technical data also on  
our website*

**TRONIX**



## Before first use

Before getting started with this product, it is advisable to check the order completeness and any damage. If this is the case, please contact Tronix Lighting.

## Description

These sturdy decorative light balls from Tronix are not only very beautiful, but also very handy. Each ball comes with a two-piece plug, allowing you to easily make a connection towards the power supply.

This allows you to easily create very atmospheric combinations.

### Features

- To be combined with pro-system modular 230V;
- Steel construction;
- Foldable design for easy storage and transportation;
- Various light colors, light types and sizes for perfect ambience experience.

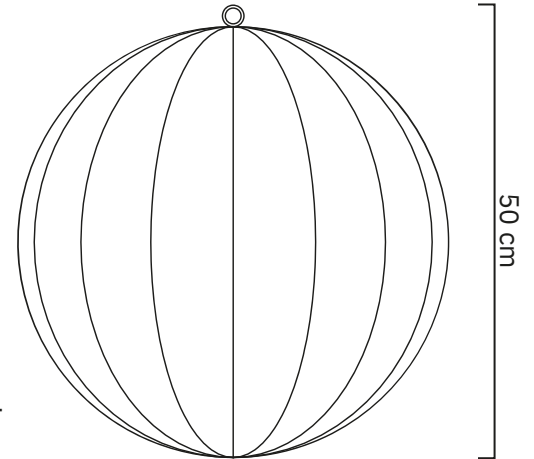

## Installation

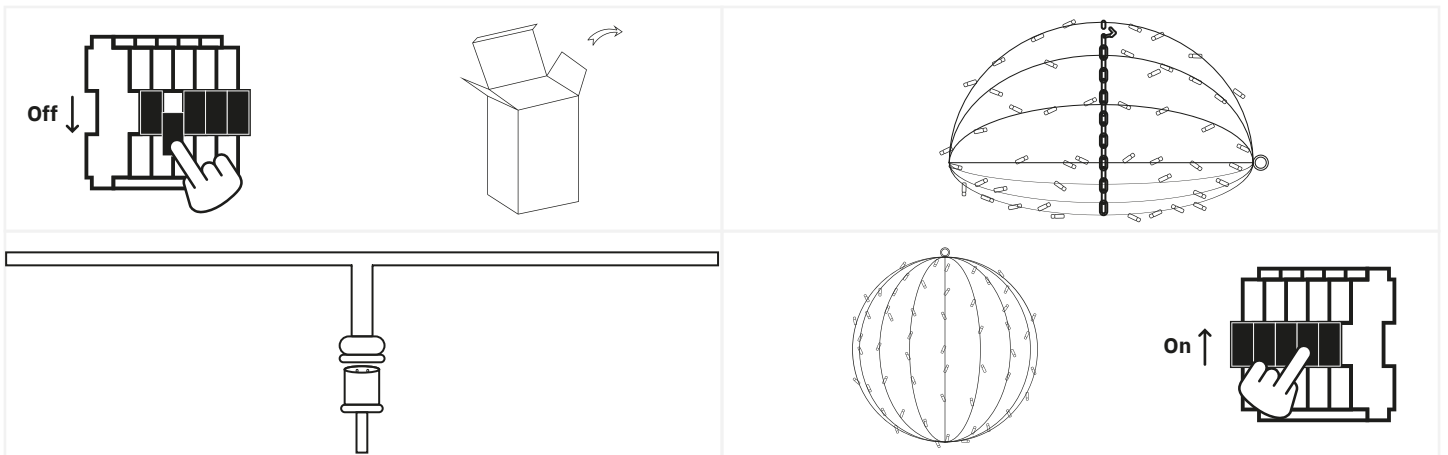

1. Turn off the power and remove the product and associated parts from the packaging.
2. Loosen the hook in the pattern and pull the sphere open. Then complete the rounding by placing the hooks in the right place;
3. Pull the wiring using the purchased PS230 cables and attach it to one or more motifs;
4. Check the complete installation. Should this be in order, you can reactivate the power.



## Safety

Safety is a top priority at Tronix Lighting. Therefore, we heartily recommend that you follow the following steps closely:

- Keep this manual carefully for future reference;
- Choose a qualified electrician while installing, maintaining or inspecting this product;
- Never look directly into a light source to avoid possible eye damage;
- Ensure that the respective power group is always on non-active when the product is connected;
- Use only recommended combinations (LED drivers, controllers or dimmers) to avoid injury or damage to the product;
- The light sources of this motif is not replaceable. Because of this, you need to replace the entire fixture towards the end of its life and it is not recommended to open it.

## Technical problems and repair

Should a product not work properly after installation, or if the product exhibits problems over time, it is advisable to check the following elements:

- Check the wiring and installation of your product;
- Check for the presence of interfering elements such as dust, water or other electronics;
- If possible, try disconnecting the product and testing it in another location to rule out a problem at the location;
- Should you be dealing with a WIFI-based product, check and reset your router's settings.

Should the product still not work after testing, it is recommended to send it in for inspection and/or repair. To do so, please contact Tronix Lighting using nearby details and proof of purchase (packing slip).



CARE



SHARE



CONNECT

### Supplier:

Tronix Lighting B.V

Vluchtoord 41  
5406 XP Uden, Netherlands

+31 (0)413 330 380  
sales@tronixlighting.com

## Terms and symbols (as relevant to product)



The **CE mark** indicates that this product complies with EU regulations on safety, health and environmental protection;



The **WEEE symbol** stands for "Waste Electrical and Electronic Equipment Regulation," a directive on the collection, recycling and recovery of electronic waste;



The **Class II symbol** indicates that this product is double insulated;

- This product has an **IP65 rating**. This means the housing is touch-safe, fully protected from dust and spray-proof (12.5 L/min) regardless of angle.